

**MECHANICAL ENGINEERING****Paper – I**

*Time Allowed : Three Hours*

*Maximum Marks : 200*

**Question Paper Specific Instructions**

*Please read each of the following instructions carefully before attempting questions :*

*There are **EIGHT** questions in all, out of which **FIVE** are to be attempted.*

*Questions no. 1 and 5 are **compulsory**. Out of the remaining **SIX** questions, **THREE** are to be attempted selecting at least **ONE** question from each of the two Sections A and B.*

*Attempts of questions shall be counted in sequential order. Unless struck off, attempt of a question shall be counted even if attempted partly. Any page or portion of the page left blank in the Question-cum-Answer Booklet must be clearly struck off.*

*All questions carry equal marks. The number of marks carried by a question/part is indicated against it.*

• *Answers must be written in **ENGLISH** only.*

• *Unless otherwise mentioned, symbols and notations have their usual standard meanings.*

*Assume suitable data, if necessary and indicate the same clearly.*

*Neat sketches may be drawn, wherever required.*

## SECTION A

- Q1. (a) What do you mean by the inversions of a kinematic chain? List down all the inversions of a single slider-crank chain. Explain briefly any two. 8
- (b) Establish the relation between path of contact and arc of contact for an involute gear. 8
- (c) State Kennedy's theorem. Locate all the instantaneous centres for the following mechanism : 8

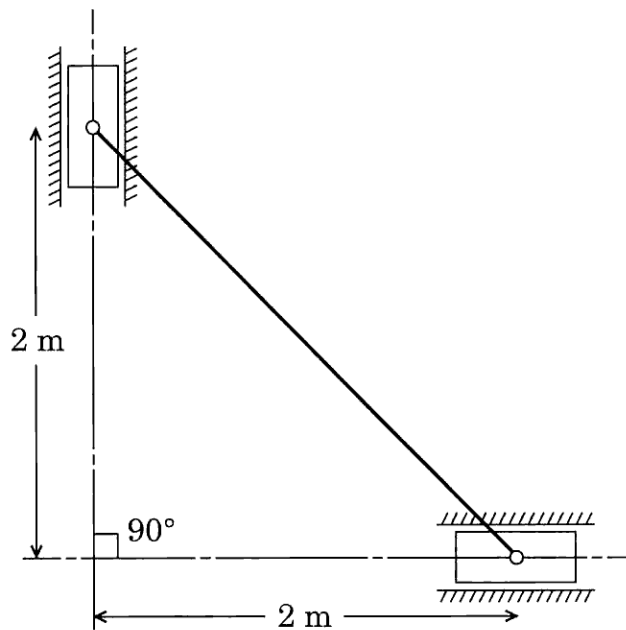

Figure Q1(c)

- (d) What are the basis for Bravais crystal structures? Enlist different unit cells and space lattices under Bravais crystal systems. 8
- (e) What are the important characteristics of aluminium? What are the important types of aluminium alloys and the elements (with percentage) used for making aluminium alloys? Which aluminium alloys are used for aerospace industries and what are their compositions? 8

- Q2.** (a) The principal stresses at a point are given as per the following figure :

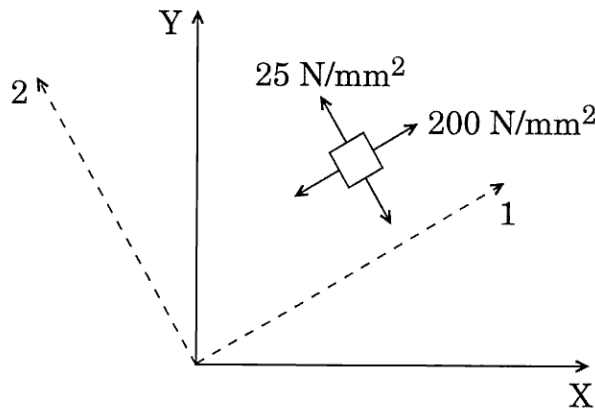

Figure Q 2(a)

Determine the state of stress w.r.t. X and Y axes. Also determine the maximum shear stress and direct stress on the plane of maximum shear. 10

- (b) Write down the equations for shear force and bending moment for various sections of the simply supported beam as shown in the figure. Also draw SFD and BMD. 10

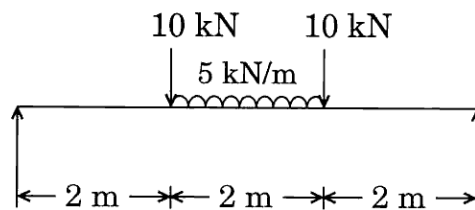

Figure Q 2(b)

- (c) In a single-acting four-stroke engine, the work done by the gases during the expansion stroke is 4 times the work done during the compression stroke. Work done during suction and exhaust stroke is negligible. The engine develops 18 kW at 240 rpm. The fluctuation of speed is limited to 1% of the mean speed on either side. The turning moment curve for compression and expansion may be assumed to be of triangular shape. Determine the MI of the flywheel. 10

- (d) Using Iron-Carbon phase diagram, illustrate the eutectoid portion and dividing point between steels and cast iron. Which elements make the steel as stainless steel ? 10

- Q3.** (a) A bar of 2 m length is rigidly fixed to a support at top section where diameter is 50 mm and remains constant up to a length of 1 m. For the remaining portion, the diameter is 25 mm. If a weight of 1000 N falls freely through 100 mm and lands uniformly on a rigid collar at the lowermost cross-section, calculate the stress and extension in the bar. Take  $E = 2.1 \times 10^5 \text{ N/mm}^2$ . 10
- (b) (i) What is an isochronous governor ? Discuss the stability of the same. 4
- (ii) Each arm of a Porter governor is 250 mm long. The upper arms are pivoted on the axis of the governor whereas the lower arms are pivoted at a distance of 20 mm from the axis. Each ball has a mass of 5 kg and the sleeve mass is 40 kg. The force of friction on the sleeve is 40 N. At the radius of rotation of balls of 140 mm, determine the range of speed for which the governor will not respond. 6
- (c) Calculate the number of atoms per unit cell of a metal having lattice parameter of 0.29 nm, density of 7.868 g/cc, atomic weight is 55.85 g/mol and Avogadro's number is  $6.023 \times 10^{23}$ . What is the crystal structure of metal ? 10
- (d) With strength vs temperature diagram show applicability of general polymers, advanced polymers, steels, aluminium, super alloys, ceramics and ceramic matrix composites. Which material will be most suitable for a part facing temperature of 1200°C in aerospace vehicles ? 10
- Q4.** (a) In what ways are composites different from alloys ? A composite is made of 40% carbon fibres by volume in epoxy matrix. The tensile strength of carbon fibres is 1650 MPa and of epoxy is 280 MPa. What will be the theoretical strength of composite ? 10
- (b) On the basis of structure, distinguish between glass, ceramics and glass-ceramics. What makes glass-ceramics an important engineering material ? 10

- (c) A simply supported beam of length  $L$  is loaded with load  $w = w_0 \sin \frac{\pi x}{L}$ , with  $x$  measured from the left support.

Determine :

10

- (i) Equation representing the deflection of the beam
- (ii) Slope at the ends
- (iii) Maximum deflection
- (d) A four-crank engine has the two outer cranks set at  $120^\circ$  to each other and their reciprocating masses are each 40 kg. The distance between the planes of rotation of adjacent cranks are 400 mm, 600 mm and 600 mm. For a complete primary balance, determine the reciprocating masses and their relative angular position of each of the inner cranks. If the length of each crank is 250 mm and the length of each connecting rod is 1 m, calculate the maximum secondary unbalanced force for a speed of rotation of 300 rpm.

10

## SECTION B

- Q5.** (a) What are the advantages of laser beam machining over conventional machining? 8
- (b) During an electric discharge drilling of a 10 mm square hole in a low carbon steel plate of 5 mm thickness, brass tool and kerosene are used. The resistance and capacitance in the relaxation circuit are  $50 \Omega$  and  $10 \mu\text{F}$ , respectively. The supply voltage is 200 volts and the gap is maintained at such a value that the discharge (sparking) takes place at 150 volts. Estimate the time required to complete the drilling operation. 8
- (c) What is Material Requirement Planning (MRP)? What are the major benefits of using MRP? 8
- (d) The cost analysis of two products A and B is given below :

Particulars	Product A	Product B
	₹	₹
Material ₹ 2.50 per unit	25	45
Labour @ ₹ 1 per hour	12	–
Labour @ ₹ 1.50 per hour	–	15
Variable overheads	2	5
Selling price	70	80

On the basis of above information, which product would you recommend to be manufactured if labour is key factor and if material is key factor? 8

- (e) Explain Static RAM, Dynamic RAM and Cache memory used in most computer systems. Also list the merits and demerits of Cache memory. 8
- Q6.** (a) During an orthogonal machining operation on mild steel, the results obtained are
- uncut chip thickness,  $t_1 = 0.25 \text{ mm}$
  - chip thickness,  $t_2 = 0.75 \text{ mm}$
  - width,  $w = 2.5 \text{ mm}$
  - rake angle,  $\alpha = 0^\circ$
  - cutting force,  $F_C = 950 \text{ N}$
  - thrust force,  $F_T = 475 \text{ N}$
- (i) Determine the coefficient of friction between the tool and the chip.
- (ii) Determine the ultimate shear stress  $\tau_s$  of the work material. 15

- (b) Given below are values of  $y$  for certain values of  $x$ . Find the equation of regression line that describes the relation between  $x$  and  $y$ . Hence estimate the value of  $y$  when  $x = 24$ .

15

$x$	2	4	6	8	10	12	14	16	18	20
$y$	13	17	24	27	28	33	35	41	43	51

- (c) (i) What do you understand by the term “tool life” ? 4  
(ii) What is the relationship between cutting speed and tool life ? 6

- Q7.** (a) A company manufactures two products A and B. Product A requires 3 man hours and 1 machine hour. Product B requires 1 man hour and 4 machine hours. The total man hours available is 50. Total machine hours available are 40. If product A gives a profit of ₹ 20 per unit and product B gives a profit of ₹ 25 per unit, write down the constraints. How many products of each type should be produced to maximise profit ? Also show the feasible region.

15

- (b) A project is represented by the network shown below and has the following data :

Task :	A	B	C	D	E	F	G	H	I
Optimistic time :	5	18	26	16	15	6	7	7	3
Pessimistic time :	10	22	40	20	25	12	12	9	5
Most likely time :	8	20	33	18	20	9	10	8	4

Determine the following :

15

- (i) Expected task times and their variance  
(ii) The critical path

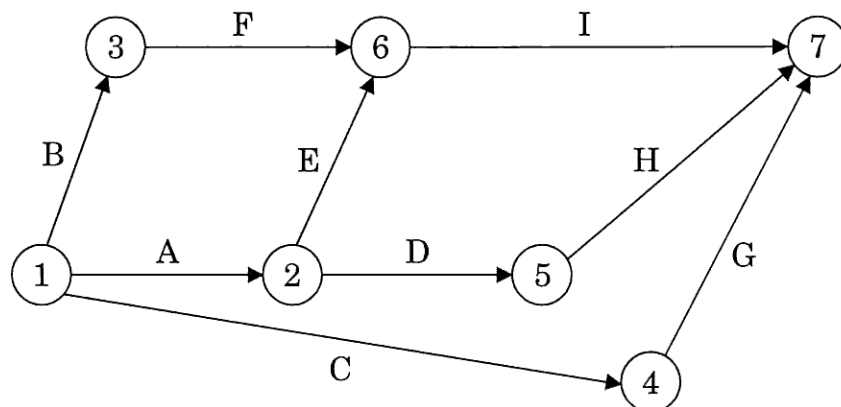

- (c) (i) What do you understand by Flexible Manufacturing System (FMS)? 3
- (ii) Which conditions are suitable for its application? 7
- Q8.** (a) The production department of a company requires 3,600 kg of raw material for manufacturing a particular item per year. It has been estimated that cost of placing an order is ₹ 36 and the cost of carrying inventory is 25 percent of the investment in the inventories. The price of investment is ₹ 10 per kg. Determine the ordering policy for raw material (i) optimal lot size, (ii) optimal order cycle time and (iii) minimum yearly variable inventory cost. 15
- (b) (i) Explain the functions served by jigs and fixtures. 7
- (ii) What is an indexing jig? 3
- (iii) Describe any two types of locators used in jigs. 5
- (c) (i) Discuss various operators used in FORTRAN language and give a brief idea about the operator's precedence. 5
- (ii) Write 'C' program to find the largest three elements from the given array and also check that array size must contain more than three elements. If array size is less than three elements then it must print that the array is invalid. 5