

ENGINEERING
EXAMINATION

DO NOT OPEN THIS TEST BOOKLET UNTIL YOU ARE ASKED TO DO SO

T.B.C. : B-HUF-P-GEA

Test Booklet Series

Serial No. 0050941

**TEST BOOKLET
ELECTRICAL ENGINEERING**



Paper—I

Time Allowed : Two Hours

Maximum Marks : 200

INSTRUCTIONS

1. IMMEDIATELY AFTER THE COMMENCEMENT OF THE EXAMINATION, YOU SHOULD CHECK THAT THIS TEST BOOKLET DOES NOT HAVE ANY UNPRINTED OR TORN OR MISSING PAGES OR ITEMS, ETC. IF SO, GET IT REPLACED BY A COMPLETE TEST BOOKLET.
2. Please note that it is the candidate's responsibility to encode and fill in the Roll Number and Test Booklet Series A, B, C or D carefully and without any omission or discrepancy at the appropriate places in the OMR Answer Sheet. Any omission/discrepancy will render the Answer Sheet liable for rejection.
3. You have to enter your Roll Number on the Test Booklet in the Box provided alongside. *DO NOT* write anything else on the Test Booklet.
4. This Test Booklet contains 120 items (questions). Each item comprises four responses (answers). You will select the response which you want to mark on the Answer Sheet. In case you feel that there is more than one correct response, mark the response which you consider the best. In any case, choose *ONLY ONE* response for each item.
5. You have to mark all your responses *ONLY* on the separate Answer Sheet provided. See directions in the Answer Sheet.
6. *All* items carry equal marks.
7. Before you proceed to mark in the Answer Sheet the response to various items in the Test Booklet, you have to fill in some particulars in the Answer Sheet as per instructions sent to you with your Admission Certificate.
8. After you have completed filling in all your responses on the Answer Sheet and the examination has concluded, you should hand over to the invigilator *only the Answer Sheet*. You are permitted to take away with you the Test Booklet.
9. Sheets for rough work are appended in the Test Booklet at the end.
10. **Penalty for wrong answers :**

THERE WILL BE PENALTY FOR WRONG ANSWERS MARKED BY A CANDIDATE.

- (i) There are four alternatives for the answer to every question. For each question for which a wrong answer has been given by the candidate, **one-third** of the marks assigned to that question will be deducted as penalty.
- (ii) If a candidate gives more than one answer, it will be treated as a **wrong answer** even if one of the given answers happens to be correct and there will be same penalty as above to that question.
- (iii) If a question is left blank, i.e., no answer is given by the candidate, there will be **no penalty** for that question.

DO NOT OPEN THIS TEST BOOKLET UNTIL YOU ARE ASKED TO DO SO

1. Permeance is inversely related to

- (a) resistance
- (b) conductance
- (c) reluctance
- (d) capacitance

2. Consider the following statements regarding an ideal core material :

- 1. It has very high permeability.
- 2. It loses all its magnetism when there is no current flow.
- 3. It does not saturate easily.

Which of the above statements are correct?

- (a) 1 and 2 only
- (b) 1 and 3 only
- (c) 2 and 3 only
- (d) 1, 2 and 3

3. The capacitance of a conducting sphere of radius r with a total charge of q uniformly distributed on its surface is

- (a) proportional to qr
- (b) independent of r
- (c) proportional to $\frac{q}{r}$
- (d) independent of q

4. The characteristic impedance of a transmission line depends upon

- (a) shape of the conductor
- (b) surface treatment of the conductor
- (c) conductivity of the material
- (d) geometric configuration of the conductor

5. In a series $R-L-C$ circuit supplied by a source of 125 V at a resonant frequency of 220 Hz, the magnitudes of the voltages across the capacitor and the inductor are found to be 4150 V. If the resistance of the circuit is 1 Ω , then the selectivity of the circuit is

- (a) 33.20
- (b) 3.32
- (c) 0.0301
- (d) 0.301

6. The value of characteristic impedance in free space is equal to

- (a) $\sqrt{\frac{\mu_0}{\epsilon_0}}$
- (b) $\sqrt{\mu_0 \epsilon_0}$
- (c) $\sqrt{\frac{1}{\mu_0 \epsilon_0}}$
- (d) $\sqrt{\frac{\epsilon_0}{\mu_0}}$

7. The magnitude of magnetic field strength H is independent of

- (a) current only
- (b) distance only
- (c) permeability of the medium only
- (d) both current and distance

8. Consider the following types of transmission lines :

1. Open-wire line
2. Twin-lead wire
3. Coaxial cable

The capacitance per metre will be least in which of the above transmission lines?

- (a) 1 only
- (b) 2 only
- (c) 3 only
- (d) 1, 2 and 3

9. Three equal point charges are located at the vertices of an equilateral triangle on the circumference of a circle of radius r . The total electric field intensity at the centre of the circle would be

- (a) zero
- (b) $\frac{3q}{4\pi\epsilon_0 r^2}$
- (c) $\frac{q}{12\epsilon_0 r^2}$
- (d) $\frac{q}{3\pi\epsilon_0 r}$

10. The Poynting vector on the surface of a long straight conductor of radius a and conductivity σ_0 , which carries current I in the z -direction, is

- (a) $\frac{I^2}{\sigma_0 \pi b^3} \hat{a}_r$ (b) $\frac{-I^2}{2\sigma_0 \pi^2 a^2} \hat{a}_r$
- (c) $\frac{-I^2}{\sigma_0 \pi^2 a^3} \hat{a}_r$ (d) $\frac{-I^2}{2\sigma_0 \pi^2 a^3} \hat{a}_r$

11. Consider the following applications in respect of a square corner reflector :

1. Radio astronomy
2. Point-to-point communication
3. TV broadcast

Which of the above applications is/are correct?

- (a) 1 only
- (b) 1 and 2 only
- (c) 2 and 3 only
- (d) 1, 2 and 3

12. The variation of $|B|$ with distance r from a very long straight conductor carrying a current I is correctly represented by

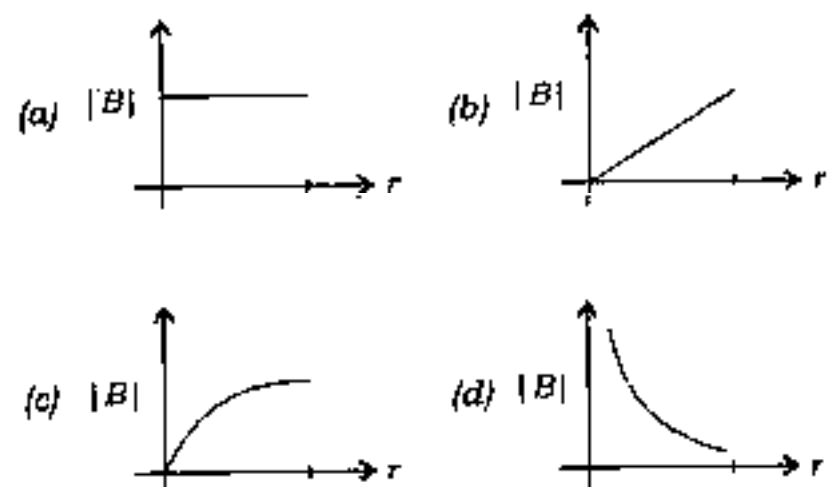

13. The resistivity of hard drawn copper at 20°C is $1.9 \times 10^{-6} \Omega \text{ cm}$. The resistivity of annealed copper compared to hard drawn copper is

- (a) lesser
- (b) slightly larger
- (c) same
- (d) much larger

14. The number of electrons excited into the conduction band from valence band (with ΔE = forbidden energy gap and k = Boltzmann's constant) is proportional to

(a) $\exp\left(\frac{\Delta E}{kT}\right)$ (b) $\exp\left(\frac{2\Delta E}{kT}\right)$

(c) $\exp\left(-\frac{\Delta E}{kT}\right)$ (d) $\exp\left(-\frac{2\Delta E}{kT}\right)$

15. Superconductivity in a material can be destroyed by

1. increasing the temperature above a certain limit
2. applying a magnetic field above a certain limit
3. passing a current above a certain limit
4. decreasing the temperature to a point below the critical temperature

Which of the above are correct?

- (a) 1 and 2 only
 (b) 2 and 3 only
 (c) 1, 2 and 3 only
 (d) 1, 2, 3 and 4

16. The relative permeability of a medium is equal to (with M = magnetization of the medium and H = magnetic field strength)

(a) $1 + \frac{M}{H}$ (b) $1 - \frac{M}{H}$

(c) $1 + \sqrt{\frac{M}{H}}$ (d) $1 - \sqrt{\frac{M}{H}}$

17. The electrical resistivity of many metals and alloys drops suddenly to zero when they are cooled to a low temperature (i.e., nearly equal to liquid helium temperature). Such materials (metals and alloys) are known as

- (a) piezoelectric materials
 (b) diamagnetic materials
 (c) superconductors
 (d) high-energy hard magnetic materials

18. The dielectric strength of rubber is 40000 V/mm at frequency of 50 Hz. What is the thickness of insulation required on an electrical conductor at 33 kV to sustain the breakdown?

- (a) 0.83 mm
 (b) 8.3 mm
 (c) 8.3 cm
 (d) 0.083 mm

19. The conductivity of insulating materials (a very small value) is called as

- (a) residual conductivity
 (b) dielectric conductivity
 (c) ionic conductivity
 (d) bipolar conductivity

20. An intrinsic semiconductor has equal number of electrons and holes in it. This is due to

- (a) doping
 (b) free electrons
 (c) thermal energy
 (d) valence electrons

21. When a very small amount of higher conducting metal is added to a conductor, its conductivity will

- (a) increase
- (b) decrease
- (c) remain the same
- (d) increase or decrease depending on the impurity

22. An electrically balanced atom has 30 protons in its nucleus and 2 electrons in its outermost shell. The material made of such atom is

- (a) a conductor
- (b) an insulator
- (c) a semiconductor
- (d) a superconductor

23. The temperature coefficient of resistance of a doped semiconductor is

- (a) always positive
- (b) always negative
- (c) zero
- (d) positive or negative depending upon the level of doping

24. In the slice processing of an integrated circuit

- (a) components are formed in the areas where silicon dioxide remains
- (b) components are formed in the areas where silicon dioxide has been removed
- (c) the diffusing elements diffuse through silicon dioxide
- (d) only on diffusion process is used

25. Permanent magnet loses the magnetic behaviour when heated because of

- 1. atomic vibration
- 2. dipole vibration
- 3. realignment of dipoles

Which of the above are correct?

- (a) 1 and 2 only
- (b) 1 and 3 only
- (c) 1, 2 and 3
- (d) 2 and 3 only

26. The magnetic field required to reduce the residual magnetization to zero is called

- (a) retentivity
- (b) coercivity
- (c) hysteresis
- (d) saturation

27. A certain fluxmeter has the following specifications :

$$\text{Air gap flux density} = 0.05 \text{ Wb/m}^2$$

$$\text{Number of turns on moving coil} = 40$$

$$\text{Area of moving coil} = 750 \text{ mm}^2$$

If the flux linking 10 turns of a search coil of 200 mm^2 area connected to the fluxmeter is reversed in a uniform field of 0.5 Wb/m^2 , then the deflection of the fluxmeter will be

- (a) 87.4°
- (b) 76.5°
- (c) 65.6°
- (d) 54.7°

28. Consider the following statements :

1. Both ferromagnetic and ferrimagnetic materials have domain structures; each domain has randomly oriented magnetic moments when no external field is applied.
2. Both ferromagnetic and ferrimagnetic materials make those domains that have favourable orientation to the applied field grow in size.
3. The net magnetic moment in ferromagnetic material is higher than that in ferrimagnetic material.
4. The net magnetic moment in ferrimagnetic material is higher than that in ferromagnetic material.

Which of the above statements are correct?

- (a) 1 and 4 only
(b) 1, 2 and 4
(c) 2 and 4 only
(d) 1, 2 and 3

29. The Hall voltage, V_H , for a thin copper plate of 0.1 mm carrying a current of 100 A with the flux density in the z-direction, $B_z = 1 \text{ Wb/m}^2$ and the Hall coefficient, $R_H = 7.4 \times 10^{-11} \text{ m}^3/\text{C}$, is

- (a) 148 μV
(b) 111 μV
(c) 74 μV
(d) 37 μV

30. A Zener regulator has an input voltage varying between 20 V and 30 V. The desired regulated voltage is 12 V, while the load varies between 140 Ω and 10 k Ω . The maximum resistance in series with the unregulated source and Zener diode would be

- (a) 3.3 Ω
(b) 66 Ω
(c) 36.6 Ω
(d) 93.3 Ω

31. A short in any type of circuit (series, parallel or combination) causes the total circuit

1. resistance to decrease
2. power to decrease
3. current to increase
4. voltage to increase

Which of the above are correct?

- (a) 2 and 3
(b) 2 and 4
(c) 1 and 4
(d) 1 and 3

32. An air-cored solenoid of 250 turns has a cross-sectional area $A = 80 \text{ cm}^2$ and length $l = 100 \text{ cm}$. The value of its inductance is

- (a) 0.425 mH
(b) 0.628 mH
(c) 0.751 mH
(d) 0.904 mH

33. The current in a coil changes uniformly from 10 A to 1 A in half a second. A voltmeter connected across the coil gives a reading of 36 V. The self-inductance of the coil is

- (a) 0.5 H
 (b) 1 H
 (c) 2 H
 (d) 4 H

34. In a mutually coupled circuit, the primary current is reduced from 4 A to zero in 10 μ s. A voltage of 40000 V is observed across the secondary. The mutual inductance between the coils is

- (a) 100 H
 (b) 10 H
 (c) 0.1 H
 (d) 0.01 H

35. N resistors each of resistance R when connected in series offer an equivalent resistance of 50 Ω and when reconnected in parallel the effective resistance is 2 Ω . The value of R is

- (a) 2.5 Ω
 (b) 5 Ω
 (c) 7.5 Ω
 (d) 10 Ω

36. For a series R - L circuit

$$i(t) = \sqrt{2} \sin(\omega t - 45^\circ)$$

If $\omega L = 1 \Omega$, the value of R is

- (a) 1 Ω
 (b) 3 Ω
 (c) $\sqrt{3} \Omega$
 (d) $3\sqrt{3} \Omega$

37. A single-phase full-wave rectifier is constructed using thyristors. If the peak value of the sinusoidal input voltage is V_m and the delay angle is $\frac{\pi}{3}$ radian, then the average value of output voltage is

- (a) $0.32V_m$ (b) $0.48V_m$
 (c) $0.54V_m$ (d) $0.71V_m$

38. The potential difference V_{AB} in the circuit

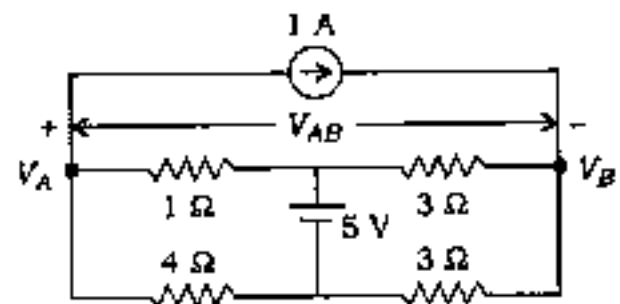

is

- (a) 0.8 V (b) -0.8 V
 (c) 1.8 V (d) -1.8 V

39. Two bulbs of 100 W/250 V and 150 W/250 V are connected in series across a supply of 250 V. The power consumed by the circuit is

- (a) 30 W (b) 60 W
 (c) 100 W (d) 250 W

40. Thevenin's equivalent of a circuit, operating at $\omega = 5$ rad/s, has

$$V_{OC} = 3.71 \angle -15.9^\circ \text{ V}$$

$$Z_O = 2.38 - j0.667 \Omega$$

At this frequency, the minimal realization of the Thevenin's impedance will have

- (a) a resistor, a capacitor and an inductor
 (b) a resistor and a capacitor
 (c) a resistor and an inductor
 (d) a capacitor and an inductor

41. Analog-to-digital converter with the minimum number of bits that will convert analog input signals in the range of 0–5 V to an accuracy of 10 mV is

- (a) 6
- (b) 9
- (c) 12
- (d) 15

42. Three $30\ \Omega$ resistors are connected in parallel across an ideal 40 V source. What would be the equivalent resistance seen by the load connected across this circuit?

- (a) $0\ \Omega$
- (b) $10\ \Omega$
- (c) $20\ \Omega$
- (d) $30\ \Omega$

43. The current $i(t)$ through a $10\ \Omega$ resistor in series with an inductance is given by

$$i(t) = 3 + 4 \sin(100t + 45^\circ) + 4 \sin(300t + 60^\circ)\ \text{A}$$

The RMS value of the current and the power dissipated in the circuit are respectively

- (a) 5 A and 150 W
- (b) 11 A and 250 W
- (c) 5 A and 250 W
- (d) 11 A and 150 W

44. Thevenin's equivalents of the network in Fig. (i) are 10 V and $2\ \Omega$. If a resistance of $3\ \Omega$ is connected across terminals AB as shown in Fig. (ii), what are Thevenin's equivalents?

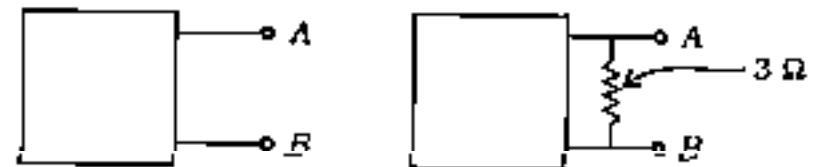

Fig. (i)

Fig. (ii)

- (a) 10 V and $1.2\ \Omega$
- (b) 6 V and $1.2\ \Omega$
- (c) 10 V and $5.2\ \Omega$
- (d) 6 V and $5.2\ \Omega$

45. A voltage source, connected to a load, has an e.m.f. of 10 V and an impedance of $(500 + j100)\ \Omega$. The maximum power that can be transferred to the load is

- (a) 0.2 W
- (b) 0.1 W
- (c) 0.05 W
- (d) 0.01 W

46. An ideal transformer is rated 220/110 V. A source of 10 V and internal impedance of $2\ \Omega$ is connected to the primary. The power transferred to a load Z_L connected across the secondary would be a maximum, when $|Z_L|$ is

- (a) $4\ \Omega$
- (b) $2\ \Omega$
- (c) $1\ \Omega$
- (d) $0.5\ \Omega$

47. Consider the following values for the circuit shown below :

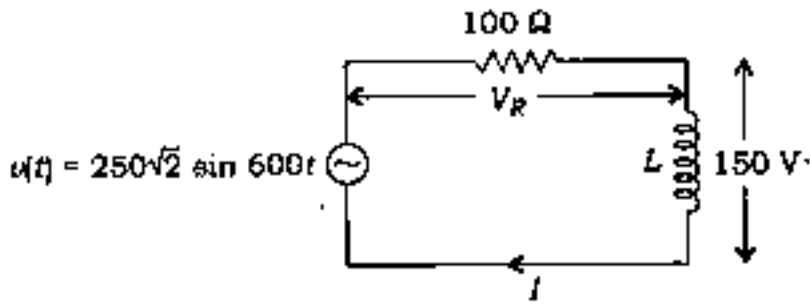

1. $V_R = 100\sqrt{2}$ V
2. $I = 2$ A
3. $L = 0.25$ H

Which of the above values are correct?

- (a) 2 and 3 only
- (b) 1 and 2 only
- (c) 1 and 3 only
- (d) 1, 2 and 3

48. The response of a series R-C circuit is given by

$$I(s) = \frac{\frac{2V}{\pi} - \frac{q_0}{C}}{R\left(s + \frac{1}{RC}\right)}$$

where q_0 is the initial charge on the capacitor. What is the final value of the current?

- (a) $\frac{1}{R}\left(\frac{2V}{\pi} - \frac{q_0}{C}\right)$
- (b) $\frac{e^{1/RC}}{R}\left(\frac{2V}{\pi} - \frac{q_0}{C}\right)$
- (c) Infinity
- (d) Zero

49. What should be done to find the initial values of the circuit variables in a first-order R-C circuit excited by only initial conditions?

- (a) To replace the capacitor by a short circuit
- (b) To replace the capacitor by an open circuit
- (c) To replace the capacitor by a voltage source
- (d) To replace the capacitor by a current source

50. In a parallel resistive circuit, opening a branch results in

1. increase in total resistance
2. decrease in total power
3. no change in total voltage and branch voltage

Which of the above is/are correct?

- (a) 1 only
- (b) 2 only
- (c) 3 only
- (d) 1, 2 and 3

51. The precision resistors are

- (a) carbon composition resistors
- (b) wire-wound resistors
- (c) resistors with a negative temperature coefficient
- (d) resistors with a positive temperature coefficient

52. In nodal analysis, the preferred reference node is a node that is connected to
1. ground
 2. many parts of the network
 3. the highest voltage source

Which of the above is/are correct?

- (a) 1 only
- (b) 2 only
- (c) 3 only
- (d) 1, 2 and 3

53. Two networks are said to be dual when

- (a) their node equations are the same
- (b) the loop equations of one network are analogous to the node equations of the other
- (c) their loop equations are the same
- (d) the voltage sources of one network are the current sources of the other

54. Reciprocity theorem is applicable to a network

1. containing R , L and C elements
2. which is initially not a relaxed system
3. having both dependent and independent sources

Which of the above is/are correct?

- (a) 1 only
- (b) 1 and 2 only
- (c) 2 and 3 only
- (d) 1, 2 and 3

55. Which of the following is true for the complete response of any network voltage or current variables for a step excitation to a first-order circuit?

- (a) It has the form $k_1 e^{-at}$
- (b) It has the form k
- (c) It may have either the form (a) or the form of (a) plus (b)
- (d) It has the form e^{+at}

56. A piezoelectric crystal has a coupling coefficient K of 0.32. How much electrical energy must be applied to produce output energy of 7.06×10^{-3} J?

- (a) 25.38 mJ
- (b) 22.19 mJ
- (c) 4.80 mJ
- (d) 2.26 mJ

57. If a constant current generator of 5 A, shunted by its own resistance of 1Ω , delivers maximum power P in watts to its load of $R_L \Omega$, then the voltage across the current generator and P are

- (a) 5 V and 6.25
- (b) 2.5 V and 12.5
- (c) 5 V and 12.5
- (d) 2.5 V and 6.25

58. Three star-connected loads of $3\angle 60^\circ \Omega$ each and three delta-connected loads of $9\angle 60^\circ \Omega$ each are connected in parallel and fed from a three-phase balanced source having line-to-neutral voltage of 120 V. The line currents drawn from the supply will be

- (a) 10 A each
- (b) 20 A each
- (c) 80 A each
- (d) 160 A each

59. A wattmeter reads 10 kW, when its current coil is connected in R phase and the potential coil is connected across R and neutral of a balanced 400 V (RYB sequence) supply. The line current is 54 A. If the potential coil reconnected across B-Y phases with the current coil in R phase, the new reading of the wattmeter will be nearly

- (a) 10 kW
- (b) 13 kW
- (c) 16 kW
- (d) 19 kW

60. The phase voltage of a three-phase, star-connected alternator is V . By mistake, the connection of R phase got reversed. The new line voltages will have a relationship

- (a) $V_{RY} = V_{BR} = \frac{V_{YB}}{\sqrt{3}}$
- (b) $V_{RY} = V_{YB} = \frac{V_{BR}}{\sqrt{3}}$
- (c) $V_{YB} = V_{BR} = \frac{V_{RY}}{\sqrt{3}}$
- (d) $V_{RY} = V_{YB} = V_{BR}$

61. Two-wattmeter method of power measurement in three-phase system is valid for

- (a) balanced star-connected load only
- (b) unbalanced star-connected load only
- (c) balanced delta-connected load only
- (d) balanced or unbalanced star- as well as delta-connected loads

62. Consider the following statements regarding the effect of adding a pole in the open-loop transfer function on the closed-loop step response :

1. It increases the maximum overshoot.
2. It increases the rise time.
3. It reduces the bandwidth.

Which of the above statements are correct?

- (a) 1, 2 and 3
- (b) 1 and 2 only
- (c) 2 and 3 only
- (d) 1 and 3 only

63. A CRO screen has 10 divisions on the horizontal scale. If a voltage signal $5 \sin(314t + 45^\circ)$ is examined with a line base setting of 5 ms/div, the number of signals displayed on the screen will be

- (a) 1.25 cycles
- (b) 2.5 cycles
- (c) 5 cycles
- (d) 10 cycles

64. A series R - L - C circuit is connected to a 25 V source of variable frequency. The circuit current is found to be a maximum of 0.5 A at a frequency of 400 Hz and the voltage across C is 150 V. Assuming ideal components, the values of R and L are respectively

- (a) 50 Ω and 300 mH
- (b) 12.5 Ω and 0.119 H
- (c) 50 Ω and 0.119 H
- (d) 12.5 Ω and 300 mH

65. The resonant frequency for the circuit

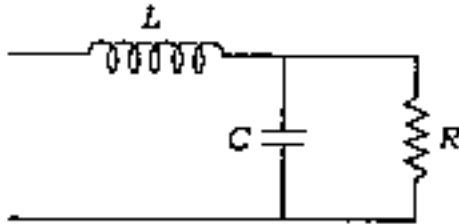

for $L = 0.2$ H, $R = 1$ Ω and $C = 1$ F, is

- (a) 1 rad/s
- (b) 2 rad/s
- (c) 3 rad/s
- (d) 4 rad/s

66. Which one of the following conditions will be correct, when three identical bulbs forming a star are connected to a three-phase balanced supply?

- (a) The bulb in R phase will be the brightest
- (b) The bulb in Y phase will be the brightest
- (c) The bulb in B phase will be the brightest
- (d) All the bulbs will be equally bright

67. For the two-port network shown in the figure

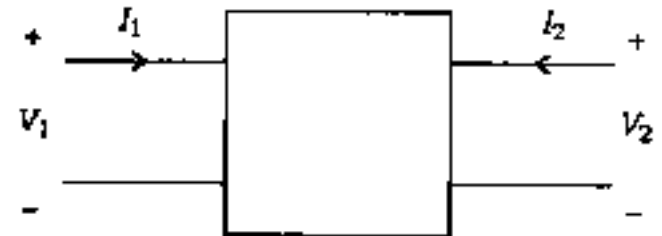

$$V_1 = 60I_1 + 20I_2 \quad \text{and} \quad V_2 = 20I_1 + 40I_2$$

Consider the following for the above network :

1. The network is both symmetrical and reciprocal.
2. The network is reciprocal.
3. $A = D$
4. $Y_{11} = \frac{1}{50}$

Which of the above is/are correct?

- (a) 2 only
- (b) 2 and 4
- (c) 1 only
- (d) 1 and 3

68. If the total powers consumed by three identical phase loads connected in delta and star configurations are W_1 and W_2 respectively, then W_1 is

- (a) $3W_2$
- (b) $\frac{W_2}{3}$
- (c) $\sqrt{3}W_2$
- (d) $\frac{W_2}{\sqrt{3}}$

69. A $100\ \mu\text{A}$ ammeter has an internal resistance of $100\ \Omega$. For extending its range to measure $500\ \mu\text{A}$, the required shunt resistance is

- (a) $10\ \Omega$
- (b) $15\ \Omega$
- (c) $20\ \Omega$
- (d) $25\ \Omega$

70. A $200\ \text{V}$ PMMC voltmeter is specified to be accurate within $\pm 2\%$ of full scale. The limiting error, when the instrument is used to measure a voltage of $100\ \text{V}$, is

- (a) $\pm 8\%$
- (b) $\pm 4\%$
- (c) $\pm 2\%$
- (d) $\pm 1\%$

71. How many poles does the following function have?

$$F(s) = \frac{s^3 + 2s + 1}{s^2 + 3s + 2}$$

- (a) 0
- (b) 1
- (c) 2
- (d) 3

72. The degree to which an instrument indicates the changes in measured variable without dynamic error is

- (a) repeatability
- (b) hysteresis
- (c) precision
- (d) fidelity

73. Loading by the measuring instruments introduces an error in the measured parameter. Which of the following devices gives the most accurate result?

- (a) PMMC
- (b) Hot-wire
- (c) CRO
- (d) Electrodynamic

74. A moving-coil galvanometer can be used as a DC ammeter by connecting

- (a) a high resistance in series with the meter
- (b) a high resistance across the meter
- (c) a low resistance across the meter
- (d) a low resistance in series with the meter

75. Consider the following types of damping :

1. Air-friction damping
2. Fluid-friction damping
3. Eddy-current damping

PMMC type instruments use which of the above?

- (a) 1 only
- (b) 2 only
- (c) 3 only
- (d) 1, 2 and 3

76. In data acquisition system, analog data acquisition system is used

- (a) for narrow frequency width, while digital data acquisition system is used when wide frequency width is to be monitored
- (b) for wide frequency width, while digital data acquisition system is used when narrow frequency width is to be monitored
- (c) when quantity to be monitored varies slowly, while its counterpart is preferred if the quantity to be monitored varies very fast
- (d) when quantity to be monitored is time-variant, while digital data acquisition system is preferred when quantity is time-invariant

77. During the measurement of resistance by Carey Foster bridge, no error is introduced due to

- 1. contact resistance
- 2. connecting leads
- 3. thermoelectric e.m.f.

Which of the above are correct?

- (a) 1 and 2 only
- (b) 1 and 3 only
- (c) 2 and 3 only
- (d) 1, 2 and 3

78. Schering bridge is a very versatile AC bridge and is used for capacitor testing in terms of

- 1. capacitance value (magnitude)
- 2. loss angle measurement
- 3. simple balance detector like PMMC instrument
- 4. providing safety to operators by incorporating Wagner earthing device

Which of the above are correct?

- (a) 1 and 3 only
- (b) 3 and 4 only
- (c) 1, 2 and 4 only
- (d) 1, 2, 3 and 4

79. Consider the following instruments :

- 1. MI instrument
- 2. Electrostatic instrument
- 3. Electrodynamometer instrument

Which of the above instruments is/are free from hysteresis and eddy-current losses?

- (a) 1 only
- (b) 2 only
- (c) 3 only
- (d) 1, 2 and 3

80. Dummy strain gauges are used for

- (a) compensation of temperature changes
- (b) increasing the sensitivity of bridge
- (c) compensating for different expansions
- (d) calibration of strain gauge

81. A wattmeter is measuring the power supplied to a circuit whose power factor is 0.7. The frequency of the supply is 50 c/s. The wattmeter has a potential coil circuit of resistance 1000 Ω and inductance 0.5 H. The error in the meter reading is

- (a) 4%
- (b) 8%
- (c) 12%
- (d) 16%

82. A moving-coil instrument gives full-scale deflection of 10 mA, when a potential difference of 10 mV is applied across its terminals. To measure currents up to 100 A, the same instrument can be used

- (a) with shunt resistance of 0.0001 Ω
- (b) with series resistance of 0.01 Ω
- (c) with shunt resistance of 0.01 Ω
- (d) with series resistance of 0.0001 Ω

83. A 400 V, three-phase, rated frequency balanced source is supplying power to a balanced three-phase load carrying a line current of 5 A at an angle of 30° lagging. The readings of the two wattmeters W_1 and W_2 , used for measuring the power drawn by the circuit, are respectively

- (a) 2000 W and 1000 W
- (b) 1500 W and 1500 W
- (c) 2000 W and 1500 W
- (d) 1500 W and 1000 W

84. A current of $-4 + 3\sqrt{2} \sin(\omega t + 30^\circ)$ A is passed through a centre zero PMMC meter and a moving-iron meter. The two meters will read respectively

- (a) -4 A and -5 A
- (b) 4 A and -5 A
- (c) -4 A and 5 A
- (d) 4 A and 5 A

85. A structural member is compressed to produce a strain of $5 \mu\text{m}/\text{m}$. The nickel wire strain gauge has a gauge factor of -12.1. The pre-stress resistance of the gauge is 120 Ω . The change in resistance due to compressive strain will

- (a) increase the resistance by 7.26 m Ω
- (b) decrease the resistance by 7.26 m Ω
- (c) increase the resistance by 49.6 m Ω
- (d) decrease the resistance by 49.6 m Ω

86. The values of ammeter and voltmeter resistances are 0.1 Ω and 2000 Ω respectively as shown in the figure below. The percentage error in the calculated value of $R = 100 \Omega$ (voltmeter reading 200 V/ammeter reading 2 A) is nearly

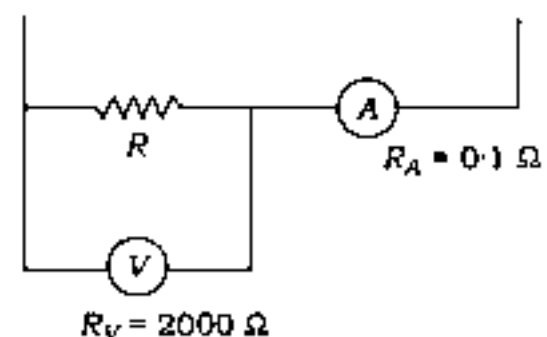

- (a) -2%
- (b) -5%
- (c) 2%
- (d) 5%

87. What is the multiplying power of a shunt of 200Ω resistance when used with a galvanometer of 1000Ω resistance?

- (a) 4
- (b) 6
- (c) 12
- (d) 20

88. The mesh-current method

1. works with both planar and non-planar circuits
2. uses Kirchhoff's voltage law

Which of the above is/are correct?

- (a) 1 only
- (b) 2 only
- (c) Both 1 and 2
- (d) Neither 1 nor 2

89. An 8-bit successive approximation A-to-D converter is driven by a 2 MHz clock. Its conversion time is

- (a) $18 \mu\text{s}$
- (b) $16 \mu\text{s}$
- (c) $8 \mu\text{s}$
- (d) $4.5 \mu\text{s}$

90. In using instrument transformers, care should be taken not to open circuit the

- (a) primary of a voltage transformer when the secondary is connected to the rated load
- (b) secondary of a voltage transformer when the primary is energized with the rated voltage
- (c) primary of a current transformer when the secondary is connected to the rated load
- (d) secondary of a current transformer when the primary is carrying the rated current

91. An inverse z-transform $x(kT)$ of

$$X(z) = \frac{1 - e^{-aT}}{(z - 1)(z - e^{-aT})}$$

is

- (a) $1 - e^{-akT}$
- (b) $1 + e^{-akT}$
- (c) $1 - e^{akT}$
- (d) $1 + e^{akT}$

92. A system has a transfer function

$$\frac{C(s)}{R(s)} = \frac{4}{s^2 + 1.6s + 4}$$

For a unit-step response and 2% tolerance band, the settling time will be

- (a) 5 seconds
- (b) 4 seconds
- (c) 3 seconds
- (d) 2 seconds

93. Consider the following statements with reference to the response of a control system :

1. A large resonant peak corresponds to a small overshoot in transient response.
2. A large bandwidth corresponds to slow response.
3. The cut-off rate indicates the ability of the system to distinguish the signal from noise.
4. Resonant frequency is indicative of the speed of transient response.

Which of the above statements are correct?

- (a) 1 and 2
- (b) 2 and 3
- (c) 1 and 4
- (d) 3 and 4

94. The open-loop transfer function of a unity feedback system is $\frac{K}{s(s+4)}$. For a damping factor of 0.5, the value of the gain K must be set to

- (a) 1
- (b) 2
- (c) 4
- (d) 16

95. For a unity feedback control system, the forward path transfer function is given by

$$G(s) = \frac{40}{s(s+2)(s^2+2s+30)}$$

The steady-state error of the system for the input $\frac{5t^2}{2}$ is

- (a) 0
- (b) ∞
- (c) $20t^2$
- (d) $30t^2$

96. When gain K of the open-loop transfer function of order greater than unity is varied from zero to infinity, the closed-loop system

- (a) may become unstable
- (b) stability may improve
- (c) stability may not be affected
- (d) will become highly stable

97. The frequency of sustained oscillation for marginal stability, for a control system

$$G(s)H(s) = \frac{2K}{s(s+1)(s+5)}$$

and operating with negative feedback, is

- (a) $\sqrt{5}$ r/s
- (b) $\sqrt{6}$ r/s
- (c) 5 r/s
- (d) 6 r/s

98. Consider the following statements :

1. Adding a zero to the $G(s)H(s)$ tends to push root locus to the left.
2. Adding a pole to the $G(s)H(s)$ tends to push root locus to the right.
3. Complementary root locus (CRL) refers to root loci with positive K .
4. Adding a zero to the forward path transfer function reduces the maximum overshoot of the system.

Which of the above statements are correct?

- (a) 1, 2 and 3 only
- (b) 3 and 4 only
- (c) 1, 2 and 4 only
- (d) 1, 2, 3 and 4

99. An R-C network has the transfer function

$$G_c(s) = \frac{s^2 + 10s + 24}{s^2 + 10s + 16}$$

The network could be used as

1. lead compensator
2. lag compensator
3. lag-lead compensator

Which of the above is/are correct?

- (a) 1 only
- (b) 2 only
- (c) 3 only
- (d) 1, 2 and 3

100. The partial fraction expansion of the function

$$F(z) = \frac{4z^2 - 2z}{z^3 - 5z^2 + 8z - 4}$$

is

- (a) $\frac{2}{z-1} + \frac{12}{(z-2)^2}$
- (b) $\frac{2}{z-1} + \frac{2}{z-2} + \frac{12}{(z-2)^2}$
- (c) $\frac{1.5}{z-1} + \frac{12}{(z-1)(z-2)}$
- (d) $\frac{1.5}{z-1} + \frac{1.5}{z-2} + \frac{1}{(z-2)^2}$

101. If an energy meter makes 5 revolutions in 100 seconds, when a load of 225 W is connected, the meter constant is

- (a) 800 rev/kWh
- (b) 222 rev/kWh
- (c) 147 rev/kWh
- (d) 13 rev/kWh

102. In a closed-loop control system

- (a) control action is independent of output
- (b) output is independent of input
- (c) there is no feedback
- (d) control action is dependent on output

103. The characteristic polynomial of a system can be defined as

- (a) denominator polynomial of given transfer function
- (b) numerator polynomial of given transfer function
- (c) numerator polynomial of a closed-loop transfer function
- (d) denominator polynomial of a closed-loop transfer function

104. For a critically damped system, the closed-loop poles are

- (a) purely imaginary
- (b) real, equal and negative
- (c) complex conjugate with negative real part
- (d) real, unequal and negative

105. A second-order position control system has an open-loop transfer function

$$G(s) = \frac{57 \cdot 3K}{s(s + 10)}$$

What value of K will result in a steady-state error of 1%, when the input shaft rotates at 10 r.p.m.?

- (a) 21.74
- (b) 10.47
- (c) 5.23
- (d) 0.523

106. Gain margin is the factor by which the system gain can be increased to drive it to

- (a) stability
- (b) oscillation
- (c) the verge of instability
- (d) critically damped state

107. Nichols' chart is used to determine

- (a) transient response
- (b) closed-loop frequency response
- (c) open-loop frequency response
- (d) settling time due to step input

108. For a type-I system, the intersection of the initial slope of the Bode plot with 0 dB axis gives

- (a) steady-state error
- (b) error constant
- (c) phase margin
- (d) cross-over frequency

109. The desirable features of a servomotor are

- (a) low rotor inertia and low bearing friction
- (b) high rotor inertia and high bearing friction
- (c) low rotor inertia and high bearing friction
- (d) high rotor inertia and low bearing friction

Directions :

Each of the following **eleven (11)** items consists of two statements, one labelled as 'Statement (I)' and the other as 'Statement (II)'. Examine these two statements carefully and select the answers to these items using the code given below :

Code :

- (a) Both Statement (I) and Statement (II) are individually true and Statement (II) is the correct explanation of Statement (I)
- (b) Both Statement (I) and Statement (II) are individually true but Statement (II) is **not** the correct explanation of Statement (I)
- (c) Statement (I) is true but Statement (II) is false
- (d) Statement (I) is false but Statement (II) is true

110. Statement (I) :

For type-II or higher systems, lead compensator may be used.

Statement (II) :

Lead compensator increases the margin of stability.

111. Statement (I) :

Stability of a system deteriorates when integral control is incorporated into it.

Statement (II) :

With integral control action, the order of a system increases and higher the order of the system, more the system tends to become unstable.

112. Statement (I) :

Self-loops can exist in block diagram but not in signal flow graph.

Statement (II) :

Both block diagrams and signal flow graphs are applicable to linear time-invariant systems.

113. Statement (I) :

The gauge factor of a strain gauge is the ratio of strain to per unit change in resistance.

Statement (II) :

Poisson's effect is defined as producing less strain with opposite sign on the plane perpendicular to the applied load.

114. Statement (I) :

Voltage is the energy per unit charge created by charge separation.

Statement (II) :

Power is energy per unit of time.

115. Statement (I) :

The electrical conductivity of a solid solution alloy drops off rapidly with increased alloy content.

Statement (II) :

A solid solution has a less regular structure than a pure metal.

116. Statement (I) :

In type-0 and type-1 systems, stable operation is possible if gain is suitably reduced.

Statement (II) :

Any one of the compensators lag, lead, lag-lead may be used to improve the performance.

117. Statement (I) :

Open-loop system is inaccurate and unreliable due to internal disturbances and lack of adequate calibration.

Statement (II) :

Closed-loop system is inaccurate as it cannot account environmental or parametric changes and may become unstable.

118. Statement (I) :

A constant temperature type hot-wire anemometer is suitable for turbulent flow measurements.

Statement (II) :

When the resistance of the hot wire is kept constant by incorporating current feedback, the bandwidth is increased.

119. Statement (I) :

Optical pyrometers are used as transducers for the measurement of flame temperature in a boiler.

Statement (II) :

Non-invasive methods are suitable for flame temperature measurement in a boiler.

120. Statement (I) :

The null voltage of an LVDT cannot be reduced to an insignificant value.

Statement (II) :

Hall effect transducers are primarily used to measure flux density.

SPACE FOR ROUGH WORK

SPACE FOR ROUGH WORK

SPACE FOR ROUGH WORK
