

**ELECTRONICS AND TELECOMMUNICATION
ENGINEERING**

Paper – I

Time Allowed : Three Hours

Maximum Marks : 300

Question Paper Specific Instructions

Please read each of the following instructions carefully before attempting questions :

*Answers must be written in **ENGLISH** only.*

*There are **EIGHT** questions divided in **TWO** sections.*

*Candidate has to attempt **FIVE** questions in all.*

*Questions no. **1** and **5** are **compulsory** and out of the remaining, **THREE** are to be attempted choosing at least **ONE** question from each section.*

The number of marks carried by a question / part is indicated against it.

Wherever any assumptions are made for answering a question, they must be clearly indicated.

Diagrams / figures, wherever required, shall be drawn in the space provided for answering the question itself.

Unless otherwise mentioned, symbols and notations carry their usual standard meanings.

Candidates should attempt all questions in the space prescribed under each question in the Question-cum-Answer (QCA) Booklet. Any answer written outside the space allotted may not be given credit.

Attempts of questions shall be counted in sequential order. Unless struck off, attempt of a question shall be counted even if attempted partly. Any page or portion of the page left blank in the Question-cum-Answer Booklet must be clearly struck off.

Values of constants which may be required :

Electron charge	= -1.6×10^{-19} Coulomb
Free space permeability	= $4\pi \times 10^{-7}$ Henry/m
Free space permittivity	= $(1/36\pi) \times 10^{-9}$ Farad/m
Velocity of light in free space	= 3×10^8 m/sec
Boltzmann constant	= 1.38×10^{-23} J/K
Planck's constant	= 6.626×10^{-34} J-s

SECTION A

- Q1.** (a) In a long semiconductor bar ($E_G = 2$ eV), conduction band electrons come in from the left in the positive x-direction with a kinetic energy of 3 eV. They move from location A to B to C to D. Between A and B, the electric field is zero; between locations B and C, there is a linearly varying voltage increase of 4 V; between C and D, the field is again zero. Assuming no scattering, sketch a simplified band diagram describing the motions of these electrons. Assuming that these electrons can be described as plane waves, with a free-electron mass, write down the wave function of the electrons at location D. Leave your result in terms of an arbitrary normalization constant. Assume the mass of free electron to be 9.11×10^{-31} kg. 12
- (b) Calculate the Fermi energy E_{FO} at 0°K for copper and estimate the average speed of the conduction electrons in Cu. The density of Cu is 8.96 gm/cm^3 and atomic weight is 63.5. Given Avogadro's number is 6×10^{23} . 12
- (c) In the common source amplifier shown, evaluate voltage gain A_v given $R_D = 2.7 \text{ k}\Omega$, $\mu = 50$ and $r_{ds} = 25 \text{ k}\Omega$. Derive the expression used. 12

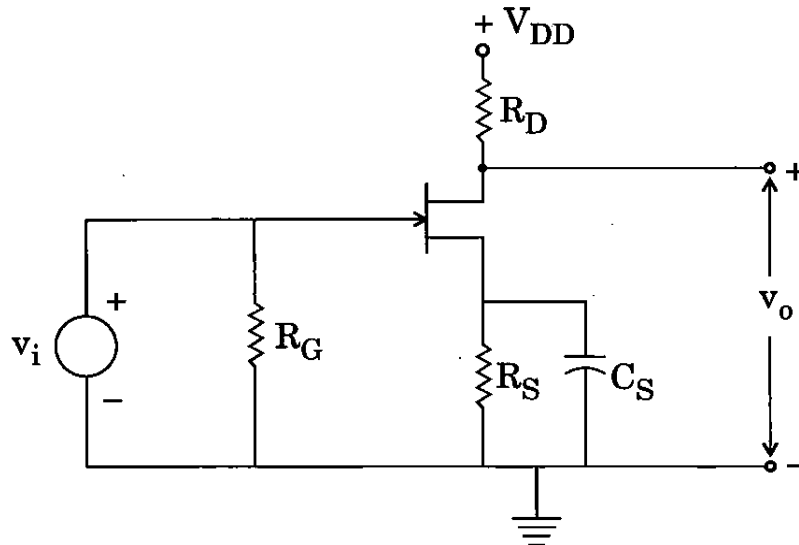

- (d) Define lumen and candela. The wavelength of visible light ranges from violet at approximately 380 nm to red at 720 nm. Obtain the bandwidth available of visible light. 12
- (e) Implement the following expression using NAND gates only : 12

$$Y = (a + c) (\bar{a} + \bar{b} + \bar{c})$$

Q2. (a) For the MOSFET characteristic shown in the figure, calculate :

- (i) Linear V_T and K_N
- (ii) Saturation V_T and K_N
- (iii) The gate oxide thickness and substrate doping.

Assume channel mobility = $500 \frac{\text{cm}^2}{\text{Vs}}$

$$V_{FB} = 0, Z = 100 \mu\text{m}, L = 2 \mu\text{m}$$

where Z is the depth of the channel and L is the length of the channel. 25

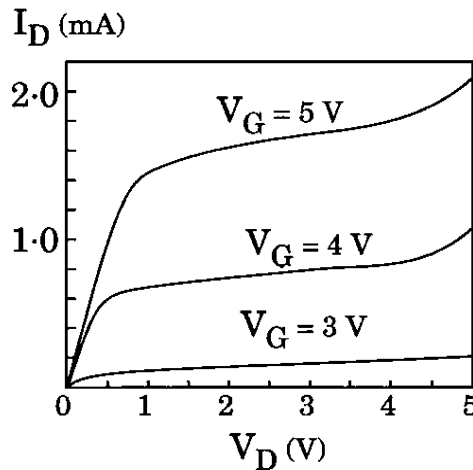

- (b) (i) What is compensated doping ?
- (ii) An n-type semiconductor containing 10^{16} phosphorus (donor) atoms/cm³ has been doped with 10^{17} boron (acceptor) atoms/cm³. Calculate the electron and hole concentrations in the semiconductor. 15

(c) Define Fan-in and Fan-out with an example. Draw the circuit diagram of an NMOS circuit to realize $f(a, b, c) = \bar{a} \bar{b} + ac$. 20

Q3. (a) (i) Consider the ac equivalent circuit of a MOSFET Colpitts oscillator.

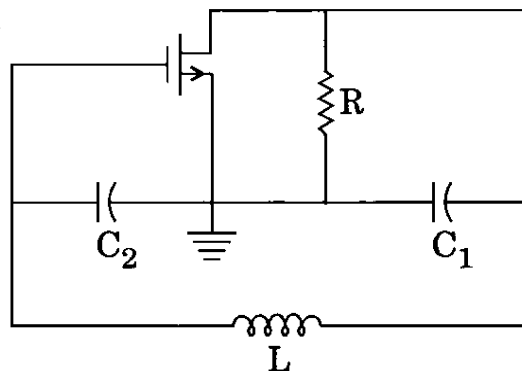

Derive the expression for oscillation frequency. Also find the condition on the gain to initiate the oscillations spontaneously.

(ii) As per the Barkhausen criterion, the positive feedback exists over a particular frequency range and the resulting feedback signal reinforces the error signal. Explain the phenomenon which limits the amplitude of the oscillations under steady state. 20

(b) A typical 1 MHz quartz crystal has the following properties :

$$f_s = 1 \text{ MHz}, \quad f_a = 1.0025 \text{ MHz}$$

$$C_o = 5 \text{ pF}, \quad R = 20 \Omega$$

The two frequencies f_s and f_a are called the series and parallel resonant frequencies. In the equivalent circuit, C_o is parallel with LCR.

What are C and L in the equivalent circuit of the crystal ?

What is the quality factor Q of the crystal ? 20

(c) What is a multiplexer ? Write the symbol and truth table of a 4-to-1 multiplexer. Implement the same using logic gates. 20

Q4. (a) Consider a CMOS inverter biased at $V_{DD} = 5 \text{ V}$ with transistor parameters of $K_N = K_P$ and $V_{TN} = -V_{TP} \approx 1 \text{ V}$. Then consider another CMOS inverter biased at $V_{DD} = 10 \text{ V}$ with the same transistor parameters. Determine the critical voltages on the voltage transfer curve of the CMOS inverter. 20

(b) If $\frac{1}{\tau}$ is defined as the mean probability per unit time that an electron is scattered, show that the mean time between collisions is τ . 15

(c) (i) The transistor circuit shown has $\beta = 100$, $V_{BE(\text{active})} = 0.7 \text{ V}$. Find the operating point (V_{CE} , I_C) and the mode of operation when S_1, S_2 are closed and S_1, S_2 are open. 10

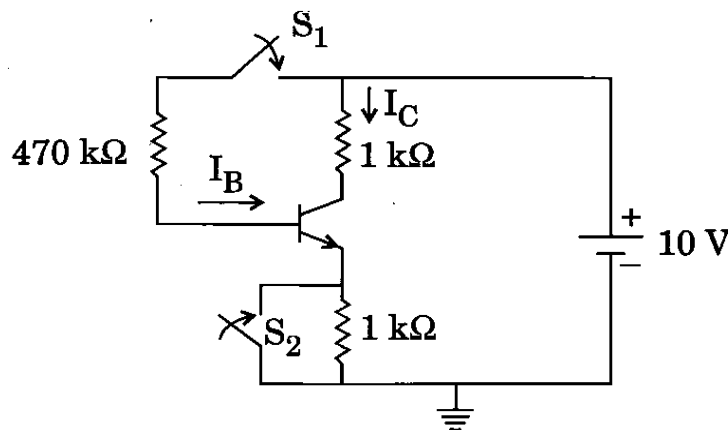

- (ii) Find the diode current I_D in the circuit shown below when the diode has cut in voltage, $V_\gamma = 0.7 \text{ V}$ and forward resistance, $R_f = 25 \Omega$.

15

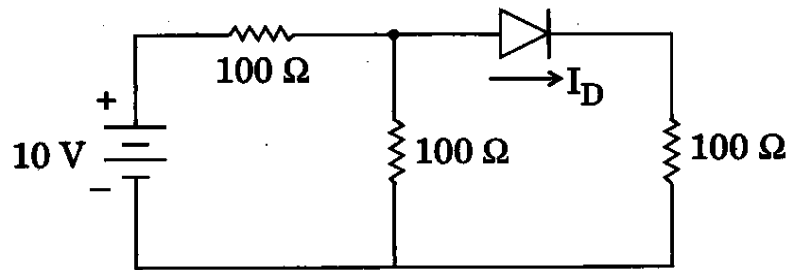

SECTION B

- Q5.** (a) Find the Thevenin resistance for the circuit shown below by zeroing the sources. Then, find the short-circuit current and the Thevenin equivalent circuit. 12

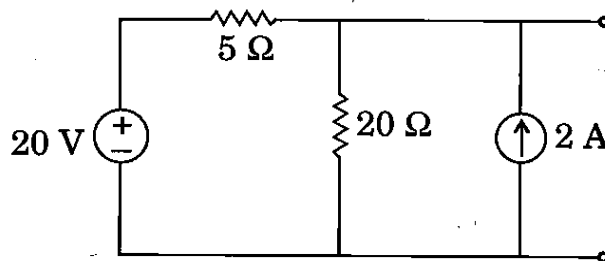

- (b) A voltmeter and an ammeter are to be used to determine the power dissipated in a resistor. Both the instruments are guaranteed to be accurate within $\pm 1\%$ at full-scale deflection. If the voltmeter reads 80 V on its 150 V range and the ammeter reads 70 mA on its 100 mA range, determine the limiting error for the power calculation. 12

- (c) The following measurements pertain to a two-port circuit operating in the sinusoidal steady state. With port 2 open, a voltage equal to $150 \cos 4000t$ V is applied to port 1. The current into port 1 is $25 \cos (4000t - 45^\circ)$ A, and the port 2 voltage is $100 \cos (4000t + 15^\circ)$ V. With port 2 short-circuited, a voltage equal to $30 \cos 4000t$ V is applied to port 1. The current into port 1 is $1.5 \cos (4000t + 30^\circ)$ A, and the current into port 2 is $0.25 \cos (4000t + 150^\circ)$ A. Find the parameters that can describe the sinusoidal steady-state behaviour of the circuit. 12

- (d) For the circuit shown in the figure, find the branch currents I_1 , I_2 and I_3 using Mesh analysis. 12

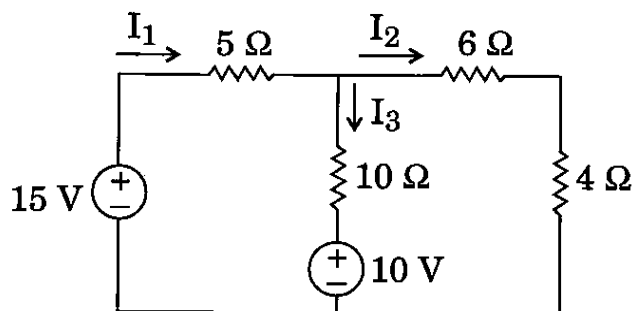

- (e) (i) Briefly discuss only the basic principles of a Thermistor and Thermocouple.
- (ii) Explain why a semiconductor has a negative resistance coefficient.

12

- Q6.** (a) (i) Use source transformations to aid in solving for the currents i_1 and i_2 shown in the circuit below.

15

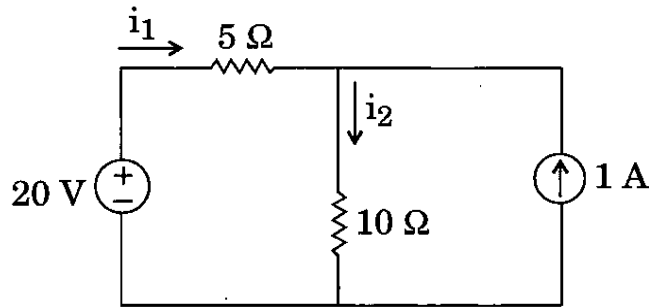

- (ii) Find the phasor voltage and the phasor current through each element in the circuit shown in the figure.

10

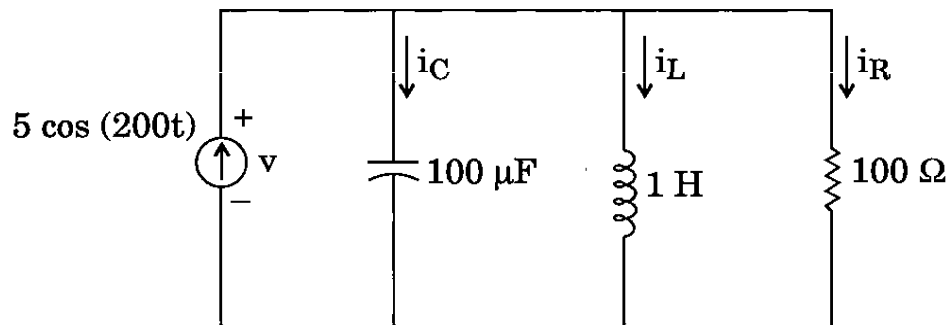

- (b) Find the equivalent resistance and capacitance that causes a Wien bridge to null with the following component values :

15

$$R_1 = 3.1 \text{ k}\Omega, R_3 = 25 \text{ k}\Omega, R_4 = 100 \text{ k}\Omega$$

$$C_1 = 5.2 \text{ }\mu\text{F} \text{ and } f = 2.5 \text{ kHz}$$

- (c) (i) The voltage source V_g drives the circuit shown in the figure. The response signal is the voltage across the capacitor, V_o . Calculate the numerical expression for the transfer function.

10

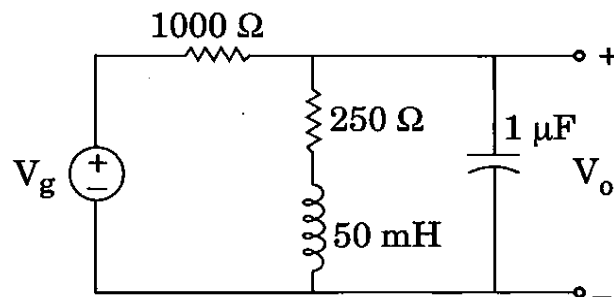

- (ii) Write down the incidence matrix and cut-set matrices for the network shown below.

10

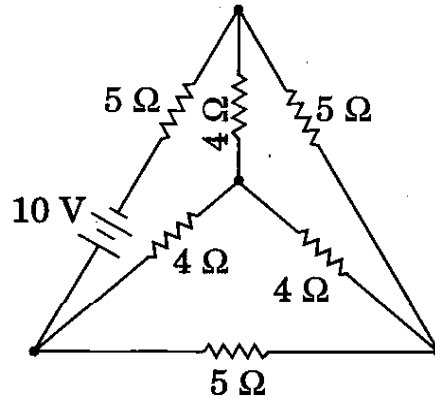

- Q7.** (a) A certain 5-hp three-phase induction motor operates from a 440-V-rms (line-to-line) three-phase source and draws a line current of 6.8 A rms at a power factor of 78 percent lagging under rated full load conditions. The full load speed is 1150 rpm. Under no-load conditions, the speed is 1195 rpm, and the line current is 1.2 A rms at a power factor of 30 percent lagging. Find the power loss and efficiency with full load, the input power with no load, and the speed regulation. 20
- (b) (i) Explain the operation of a Voltage-to-Frequency Converter. Give the primary advantages and limitations of voltage-to-frequency converters.
- (ii) The relationship between the input voltage v_i and the output frequency f for the VCO is given as $v_i = f / 50$.
If 530 pulses are passed by the AND gate during 0.1 sec gating pulse, what is the amplitude of v_i ? 20
- (c) For the circuit shown in the figure below, let $v_c(0) = 15$ V. 10
- (i) Find v_c , v_x and i_x for $t > 0$.

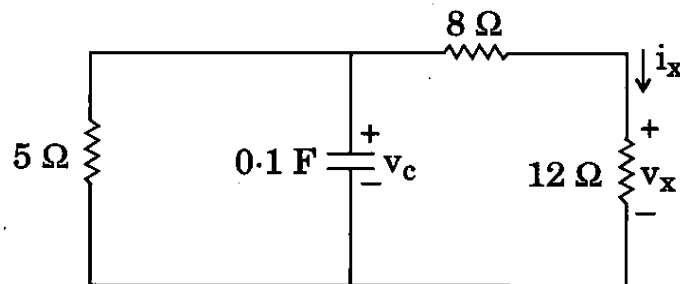

(ii) Compute V_1 and V_2 in the circuit shown below.

10

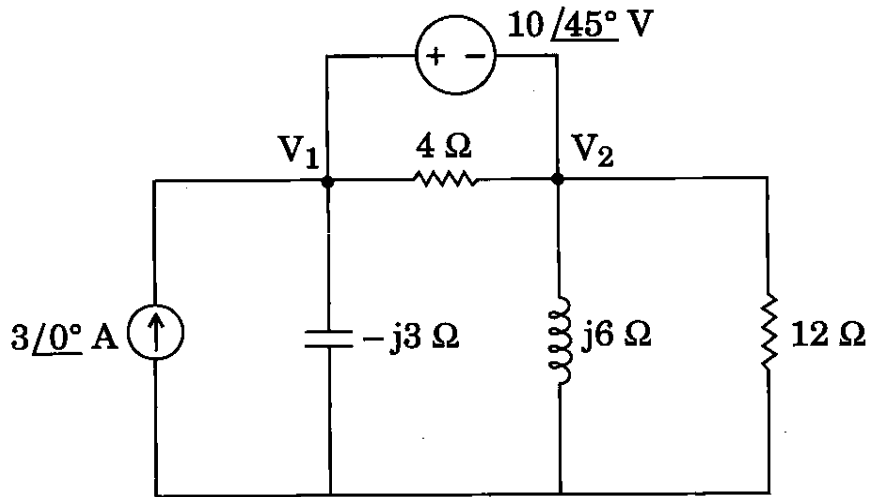

Q8. (a) (i) Two coils are wound on a toroidal core as illustrated in the figure below. The reluctance of the core is 10^7 (ampere-turns)/Wb. Determine the self-inductances and mutual inductance of the coils. Assume that the flux is confined to the core so that all of the flux links both the coils.

10

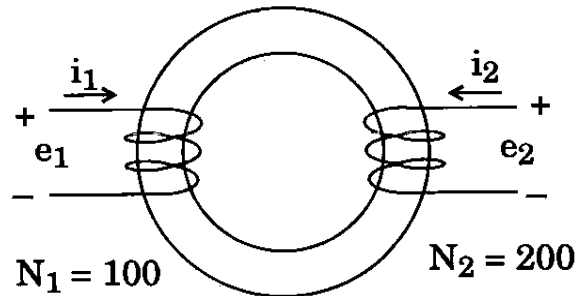

(ii) Consider the source, transformer and load shown in the figure below. Determine the rms values of the currents and voltages, (case-1) with the switch open and (case-2) with the switch closed.

10

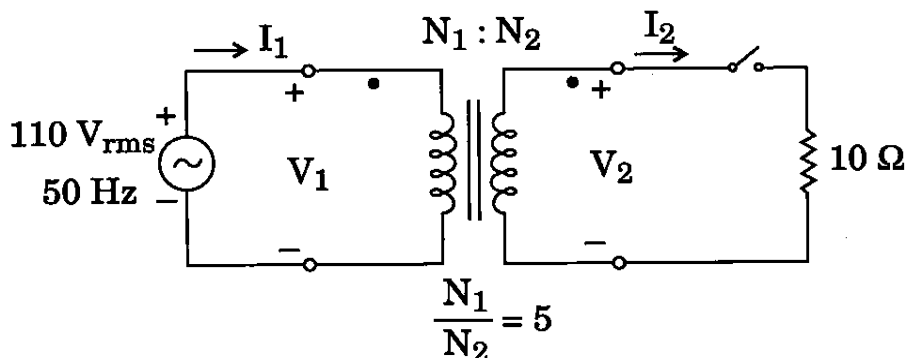

- (b) (i) Describe sampling oscilloscope and storage oscilloscope in brief.
- (ii) If, in the figure given below, the distance Y_1 is 1.8 cm and Y_2 is 2.3 cm, what is the phase angle using the X-Y mode of oscilloscope?

15

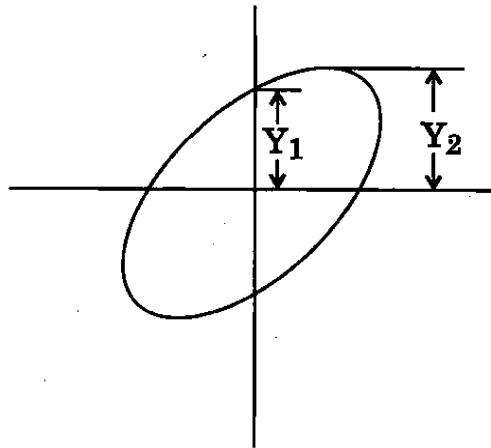

- (c) For the S-domain circuit shown in the figure, find : (i) the transfer function $H(s) = V_o / V_i$, (ii) the impulse response, (iii) the response when $v_i(t) = u(t)$ V, and (iv) the response when $v_i(t) = 8 \cos 2t$ V.

25

