

ENGINEERING SERVICES
EXAMINATION (M)2018

वियोज्य DETACHABLE

CIVIL ENGINEERING

Paper I

Time Allowed : Three Hours

Maximum Marks : 300

QUESTION PAPER SPECIFIC INSTRUCTIONS

Please read each of the following instructions carefully before attempting questions.

Answers must be written in ENGLISH only.

There are EIGHT questions divided in TWO Sections.

Candidate has to attempt FIVE questions in all.

Questions No. 1 and 5 are compulsory and out of the remaining, THREE are to be attempted choosing at least ONE question from each Section.

The number of marks carried by a question/part is indicated against it.

Answers must be written in the medium authorized in the Admission Certificate which must be stated clearly on the cover of this Question-cum-Answer (QCA) Booklet in the space provided.

No marks will be given for answers written in a medium other than the authorized one.

Wherever any assumptions are made for answering a question, they must be clearly indicated.

Diagrams/figures, wherever required, shall be drawn in the space provided for answering the question itself.

Unless otherwise mentioned, symbols and notations carry their usual standard meanings. Attempt of questions shall be counted in sequential order. Unless struck off, attempt of a question shall be counted even if attempted partly. Any page or portion of the page left blank in the Question-cum-Answer Booklet must be clearly struck off.

SECTION 'A'

- 1.(a) (i) List out at least eight tests required to determine the suitability of stone for engineering use. 8
(ii) Briefly explain the purpose and the procedure for Attrition Test on stone. 4
- 1.(b) A very long steel drill pipe got stuck in hard clay at an unknown depth. The drill pipe was applied a large upward force and observed that the drill pipe came out elastically by 500 mm. It was also observed that there was elongation of 0.04 mm in a gauge length of 200 mm. Estimate the depth of hard clay bed. Following consideration may be taken into account :
Resistance offered by all material/elements may be taken as zero. 12

1.(c)

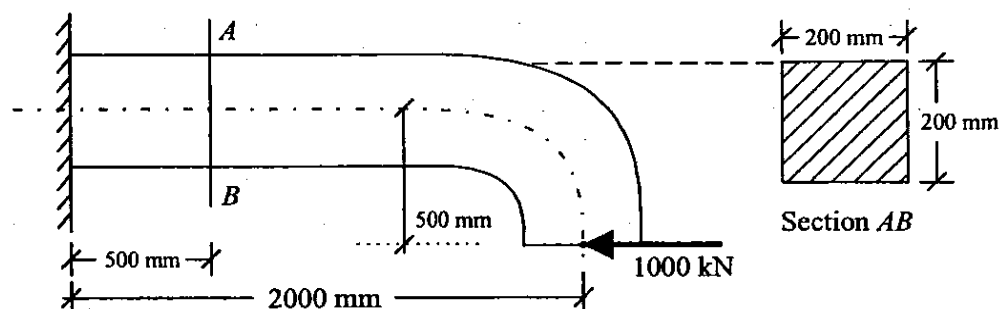

A bracket has been loaded as shown in figure. Compute the top and bottom fibre stress at section A-B.

12

- 1.(d) A beam AB is simply supported over a span of 15 m. An u.d.l of 25 kN/m intensity and 5 m length moves over the beam from end A to B . Draw the influence line diagram for bending moment and shear force at section C located at 6 m from end A . Hence calculate the maximum bending moment and shear force at section C . 12

1.(e)

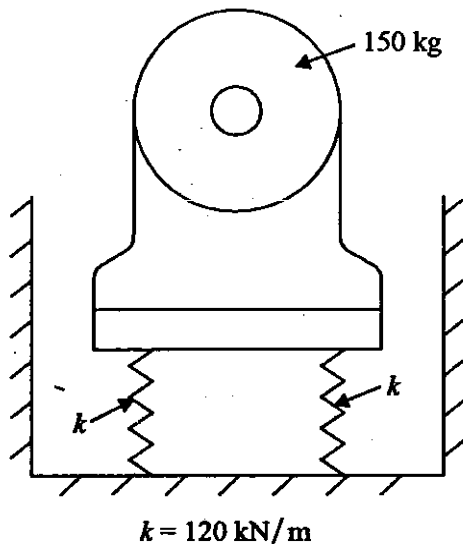

A motor of 150 kg mass is supported by four springs as shown in figure. Each of the springs has a stiffness of 120 kN/m. The unbalance of the rotor is equivalent to a mass of 40 g located at 150 mm from the axis of rotation. The motor is constrained to move vertically. Find

- (i) the speed of motor at which resonance will occur
- (ii) the amplitude of vibration of the motor when the speed is 1000 rev./m. 12

- 2.(a) (i) List out eight chemical ingredients of Portland cement and briefly explain their functions. 12
(ii) What are Bogue's compounds? Briefly mention their functions. 8

- 2.(b) A square bar (50 mm \times 50 mm cross-section) of 100 mm length is subjected to an axial compressive load of 10 kN. Calculate the change in volume of the bar, if all lateral strains of the bar are prevented by a uniform pressure on its four lateral faces. Calculate this pressure value and the change in volume. Also calculate the value of bulk modulus K and shear modulus G for the material of bar. Following parameters may be used if required.

1. $E = 2 \times 10^5 \text{ N/mm}^2$

2. $\mu = 0.25$ 20

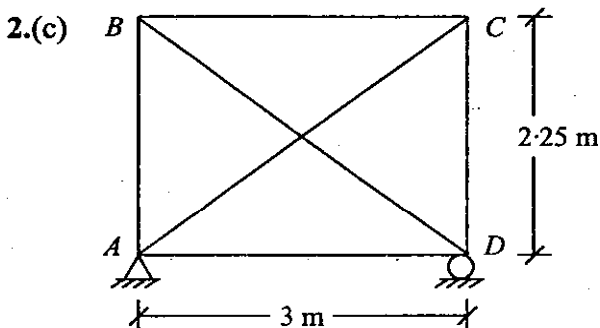

The frame shown in figure is fabricated using members with cross-sectional areas as given below :

Diagonal members = 2000 sq. mm

Other members = 1000 sq. mm

E for the material of members = $2 \times 10^5 \text{ N/sq. mm}$

Member AC was fitted last and the length of the member was 1 mm short. Determine the forces developed in the members when AC was pulled and fitted in position. 20

- 3.(a) (i) Briefly explain Thermoplastic and Thermosetting materials. 4
(ii) List out six differences between them. 8
(iii) Briefly explain manufacture of Aluminium and state at least six physical and mechanical properties of Aluminium. 8

- 3.(b) In a steel flat plate a state of plane stress available. Calculate σ_y and principal stresses if $\sigma_x = 140 \text{ N/mm}^2$, $\mu = 0.25$, $\tau_{xy} = 40 \text{ N/mm}^2$, $\epsilon_z = -3.6 \times 10^{-4}$ and $E = 2 \times 10^5 \text{ N/mm}^2$. 20

3.(c)

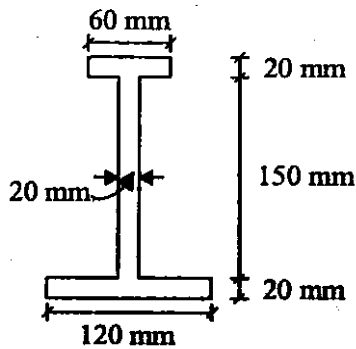

A beam of unsymmetrical I section shown in figure is simply supported over a span of 8 m. It carries a uniformly distributed load of 20 kN/m over the entire span. Draw the sketch for shear stress variation across the depth of the cross-section located at a distance of 3 m from left end A. 20

- 4.(a) A single solid circular shaft 400 mm diameter running at 200 RPM, is to be replaced by two hollow circular shafts of equal size running at 100 RPM and developing 50% additional power. The internal diameter of hollow shaft may be taken as one third of their external diameters. If the working stress of the new shaft is 30% greater than that of the former, find the external and internal diameters of the hollow shafts. 20

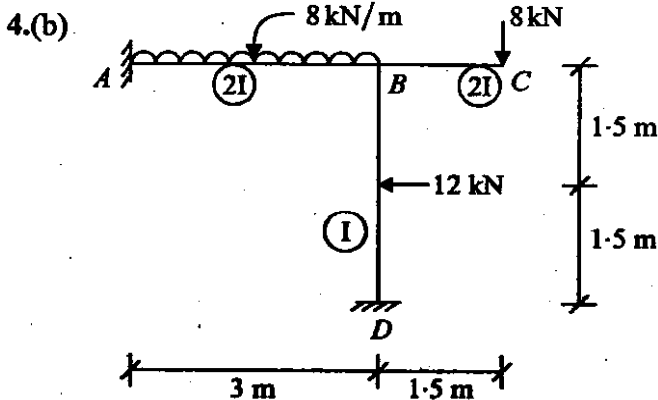

Analyse the frame shown in figure by slope deflection method and draw the B.M.D. and S.F.D. 20

- 4.(c) (i) Distinguish between Flexibility Method and Stiffness Method used for analysis of structures. 4

(ii)

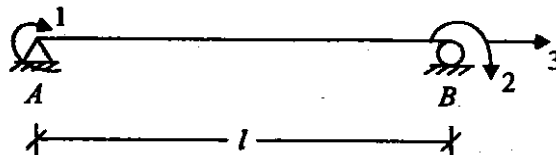

Briefly explain the procedure and then develop the stiffness matrix for the beam element shown in figure with respect to the degrees of freedom 1, 2 and 3. The cross-sectional area A and flexural rigidity EI are constant for the beam. 16

SECTION 'B'

- 5.(a) Find the shape factor of a triangular section of base b and height h for bending about an axis parallel to the base. 12

5.(b) A construction project has the following characteristics :

12

Activity	Preceding Activity	Duration (weeks)
A	None	5
B	A	2
C	A	6
D	B	12
E	D	10
F	D	5
G	D	5
H	B	9
I	C, E	1
J	G	2
K	F, I, J	3
L	K	9
M	H, G	7
N	M	9

- Draw a network for this project
- Find various paths and the critical path as well as the project completion time
- Prepare an activity schedule showing Earliest Start time, Earliest Finish time, Latest Start time, Latest Finish time and float for each activity.
- Will the critical path change if activity G takes 10 weeks instead of 5 weeks ? If so, what will be the new critical path ?

5.(c)

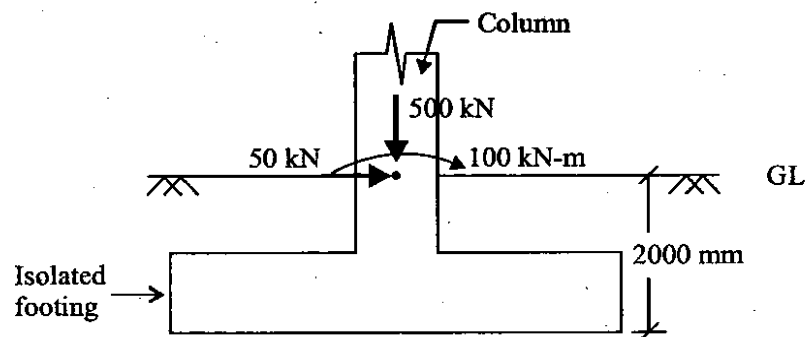

An isolated footing is transferring load from a column (300 mm × 300 mm) as shown in figure. Arrange the plan dimensions of footing so that there will be uniform soil pressure intensity. Following parameters may be used.

- Column size : 300 mm × 300 mm
- Safe Bearing capacity : 100 kN/m²
- Dead weight of footing and soil weight over it may be taken as 10% of vertical load of column.

12

5.(d) An ISMB 400 beam is spliced at a section carrying factored bending moment of 120 kNm and factored shear force of 80 kN. The splice is to be designed so that the flange splice will carry the bending moment and the web splice will carry the shear force. Field welding with 8 mm fillet will be used. Determine the size of 100 mm wide flange plate using the following data :

$t_f = 16$ mm; $t_w = 8.9$ mm and $b_f = 140$ mm.

12

5.(e) A cylindrical water tank of capacity 500 m^3 is resting on ground and have a free-flexible joint at base (vertical wall-base slab connection). Overall height of tank is restricted to 4.3 m (it includes a free board of 0.3 m). Design the vertical cylindrical wall of tank only. Following parameters may be used for design, if required :

1. $\sigma_{cbc} = 10 \text{ N/mm}^2$
2. $\sigma_{cbr} = 2.0 \text{ N/mm}^2$
3. $\sigma_{ct} = 1.5 \text{ N/mm}^2$
4. $\sigma_{st} = 130 \text{ N/mm}^2$
5. $\gamma_w = 10 \text{ kN/m}^3$
6. Main reinforcing bar diameter : 16 mm
7. $m = 10$.

12

6.(a)

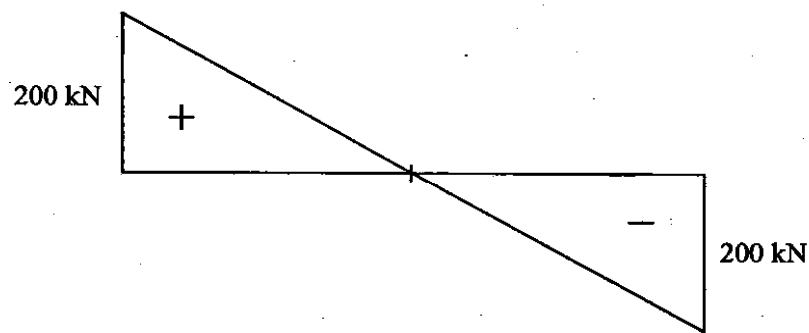
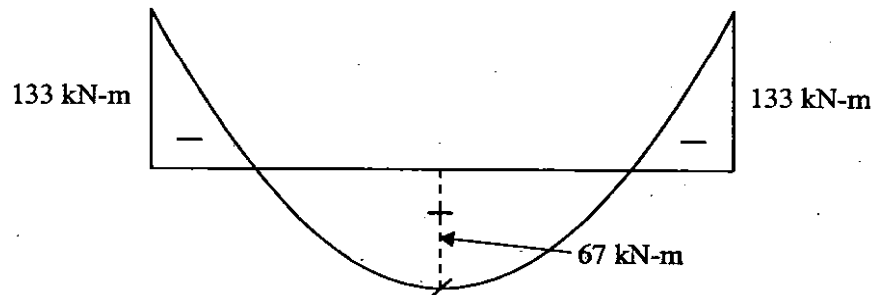

Design the reinforcement at critical section only for a beam for which Bending moment and shear force diagram has been shown in figure. Following parameter may be used for design :

1. M-20 grade concrete
2. Fe-415 grade steel
3. Nominal concrete cover : 30 mm
4. (Depth/width) ratio of beam : 0.2
5. Diameter of reinforcing bar : 20 mm for flexure reinforcement and 8 mm for shear reinforcement.
6. Shear strength of concrete = 0.6 N/mm^2
7. $(Mu, \lim/f_{ck} bd^2) = 0.138$
8. $(pt, \lim f_y/f_{ck}) = 19.82$.

20

6.(b)

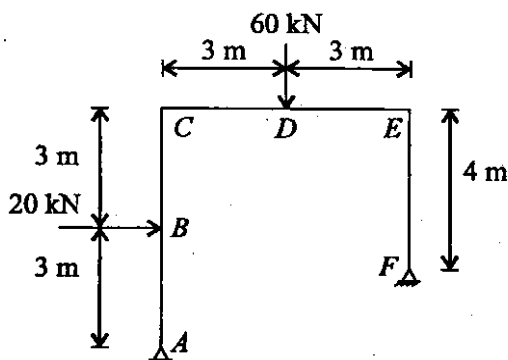

Find the collapse load for a frame of uniform cross-section shown in figure under the applied forces. Also determine the minimum section in steel required to resist the applied forces. 20

6.(c)

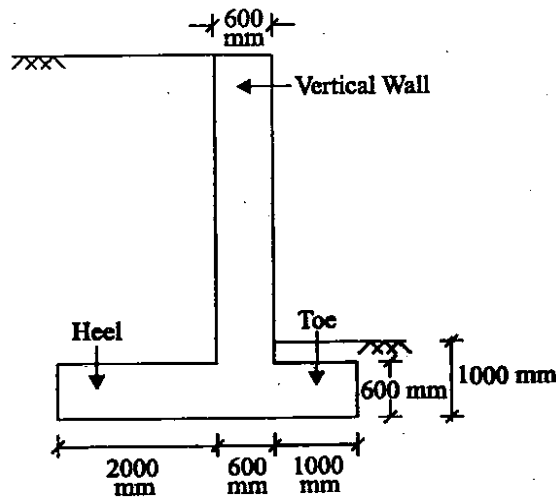

Design and sketch the reinforcement in vertical wall, Toe slab and Heel slab (for maximum Bending moment and maximum shear force only) for the cantilever retaining structure shown in figure. Following parameters may be used for design and sketch :

1. Maximum Bending moment in vertical wall : 400 kN-m, Toe : 160 kN-m and in Heel : 200 kN-m.
2. Maximum shear force in vertical wall : 200 kN, Toe : 120 kN and in Heel : 160 kN.
3. Grade of concrete M-20.
4. Grade of reinforcing bar Fe 415.
5. Nominal concrete cover 20 mm.
6. Development length : $47 \times$ diameter of bar.
7. Diameter of main bar in vertical wall : 25 mm, in Heel : 25 mm and in Toe : 25 mm.
8. $(Mu, \lim / f_{ck} bd^2) = 0.138$.
9. $(pt, \lim f_y / f_{ck}) = 19.82$.
10. Shear strength of concrete = 0.60 N/mm².

20

7.(a) Write in brief the principles of Dragline and Clamshell used as excavation equipments, the detail of their components and neat sketches showing their parts. How both the equipments can be compared ?

20

7.(b)

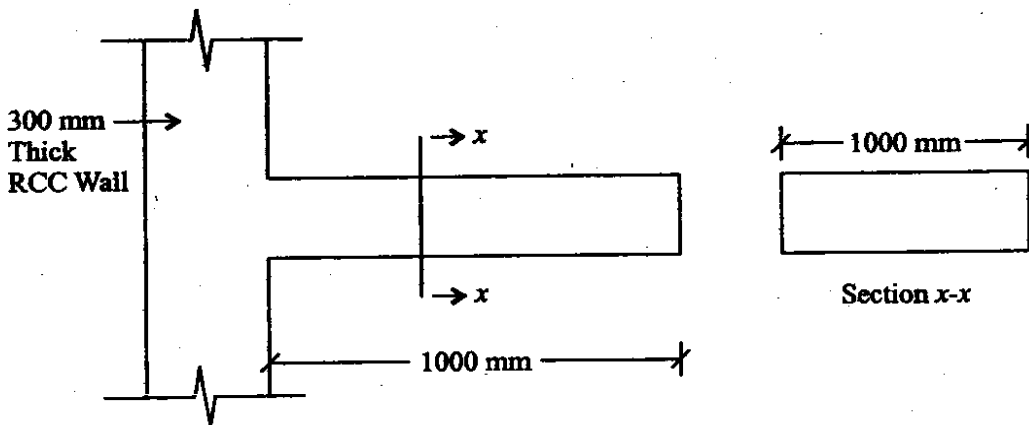

Design a cantilever slab shown in figure for flexure only. Sketch the reinforcement also. Following parameters may be used for design, applying different checks and detailing the reinforcement :

1. Span to effective depth : 10 (maximum)
2. Mild exposure condition : Nominal concrete cover 20.0 mm
3. 2.0 Hours of fire resistance : Nominal concrete cover 25.00 mm
4. Maximum live load : 30 kN/m²
5. Load combination : $1.5 \times$ Dead load + $1.5 \times$ live load
6. Effective length : length to the face of support plus half the effective depth
7. Grade of concrete M-20
8. Grade of reinforcing steel Fe-415
9. Unit weight of RCC : 25 kN/m³
10. Development length in Tension : $48 \times$ diameter of reinforcing bar
11. Development length in compression : $37 \times$ diameter of bar
12. Minimum reinforcement : 0.12% of total cross-sectional area
13. Maximum spacing of main reinforcement : $3 \times$ effective depth
14. Maximum spacing of distribution reinforcement : $5 \times$ effective depth
15. Diameter of main reinforcing bar : 10 mm
16. $(Mu, \lim / f_{ck} bd^2) = 0.138$
17. $(pt, \lim f_y / f_{ck}) = 19.82$.

20

- 7.(c) A laced column consisting of two ISMC 300 channels placed back-to-back is subjected to factored axial load of 1100 kN. The 10 m long column is restrained in translation but not in rotation at ends. Single lacing at 45° is provided, and connected to flanges by bolts. Verify the capacity of the selected section and determine their spacing. Also determine the size of 50 mm wide lacing rods considering only compressive force in them. Take $f_y = 250$ MPa and gauge length of lacing rods = 50 mm. The properties of ISMC 300 are as follows : $A = 4630$ mm², $B = 90$ mm, $t = 7.8$ mm, $T = 13.6$ mm, $\alpha = 96^\circ$, $C_y = 23.5$ mm, $I_{xx} = 6.42 \times 10^7$ mm⁴, $I_{yy} = 3.13 \times 10^6$ mm⁴, $r_x = 118.0$ mm, $r_y = 26.0$ mm. Do not design the connection of lacing rod to the channel member. Table 9(c) of IS : 800 is enclosed for reference. 20

- 8.(a) (i) What is a work breakdown structure in Construction Project Management ? Define and explain in brief. Further, how Work Breakdown Structure is classified into different levels for making the job convenient ? Explain with an example. 12
- (ii) What is Resource Levelling in Construction Project Management and how it is different than Resource Loading ? 8

8.(b)

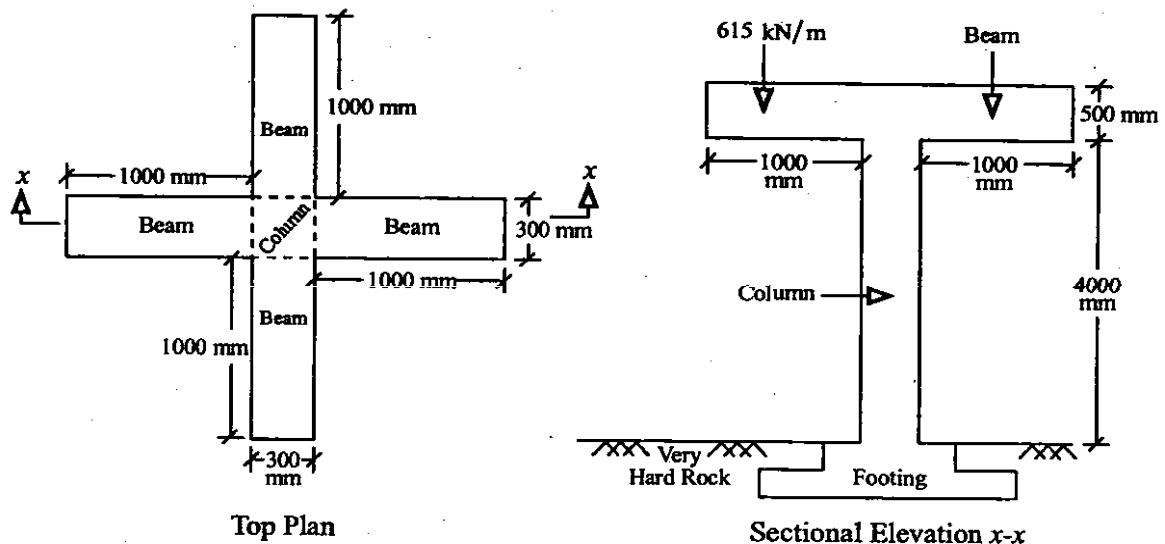

A square column (500 mm × 500 mm) carries load from two beams, which are mutually perpendicular as shown in figure. Overhang portion of beams carry a total load of 615.0 kN/m (include self-weight). Design the column at top of footing level. Footing is fully embedded in very hard rock. Beams are restrained against rotation at Beam-column junction. The minimum eccentricity is less than 0.05 times the lateral dimension of column. Sketch all details required at column cross-section.

Use : M-20 grade concrete, Fe-415 grade reinforcing bars, Appropriate coefficient form 1.0/1.20/1.50/2.0, Main reinforcing bar : 32 mm diameter. 20

- 8.(c) Determine the ultimate bending moments and forces due to vertical and horizontal loads that act on a simply-supported gantry girder. Use the following data :
1. Simply supported span = 6 m
 2. Distance between crane wheels = 3.6 m
 3. Self-weight of girder = 1.5 kN/m
 4. Maximum crane wheel load (static) = 220 kN
 5. Weight of crab/trolley = 60 kN
 6. Maximum hook load = 200 kN
- Take impact factor of 25% and assume double flanged wheels $e = 0.15$ m while the girder depth, $D = 0.60$ m. 20

Table 9(c) Design Compressive Stress, f_{cd} (MPa) for Column Buckling Class c

KL/r ↓	Yield Stress, f_y (MPa)																			
	200	210	220	230	240	250	260	280	300	320	340	360	380	400	420	450	480	510	540	
10	182	191	200	209	218	227	236	255	273	291	309	327	345	364	382	409	436	464	491	
20	182	190	199	207	216	224	233	250	266	283	299	316	332	348	364	388	412	435	458	
30	172	180	188	196	204	211	219	234	249	264	278	293	307	321	335	355	376	395	415	
40	163	170	177	184	191	198	205	218	231	244	256	268	280	292	304	320	337	352	367	
50	153	159	165	172	178	183	189	201	212	222	232	242	252	261	270	282	295	306	317	
60	142	148	153	158	163	168	173	182	191	199	207	215	222	228	235	244	252	260	267	
70	131	136	140	144	148	152	156	163	170	176	182	187	192	197	202	208	213	218	223	
80	120	123	127	130	133	136	139	145	149	154	158	162	165	169	172	176	180	183	186	
90	108	111	114	116	119	121	123	127	131	134	137	140	142	144	146	149	152	154	156	
100	97.5	100	102	104	105	107	109	112	114	116	119	120	122	124	125	127	129	131	132	
110	87.3	89.0	90.5	92.0	93.3	94.6	95.7	97.9	100	102	103	104	106	107	108	110	111	112	113	
120	78.2	79.4	80.6	81.7	82.7	83.7	84.6	86.2	87.6	88.9	90.1	91.1	92.1	93.0	93.8	94.9	95.9	96.8	97.6	
130	70.0	71.0	71.9	72.8	73.5	74.3	75.0	76.2	77.3	78.3	79.2	80.0	80.7	81.4	82.0	82.9	83.6	84.3	84.9	
140	62.9	63.6	64.4	65.0	65.6	66.2	66.7	67.7	68.6	69.3	70.0	70.7	71.2	71.8	72.3	72.9	73.5	74.1	74.6	
150	56.6	57.2	57.8	58.3	58.8	59.2	59.7	60.4	61.1	61.7	62.3	62.8	63.3	63.7	64.1	64.6	65.1	65.5	65.9	
160	51.1	51.6	52.1	52.5	52.9	53.3	53.6	54.2	54.8	55.3	55.7	56.1	56.5	56.9	57.2	57.6	58.0	58.4	58.7	
170	46.4	46.8	47.1	47.5	47.8	48.1	48.4	48.9	49.3	49.8	50.1	50.5	50.8	51.1	51.3	51.7	52.0	52.3	52.6	
180	42.2	42.5	42.8	43.1	43.4	43.6	43.9	44.3	44.7	45.0	45.3	45.6	45.8	46.1	46.3	46.6	46.9	47.1	47.3	
190	38.5	38.8	39.0	39.3	39.5	39.7	39.9	40.3	40.6	40.9	41.1	41.4	41.6	41.8	42.0	42.2	42.5	42.7	42.9	
200	35.3	35.5	35.7	35.9	36.1	36.3	36.5	36.8	37.0	37.3	37.5	37.7	37.9	38.1	38.2	38.4	38.6	38.8	39.0	
210	32.4	32.6	32.8	33.0	33.1	33.3	33.4	33.7	33.9	34.1	34.3	34.5	34.7	34.8	34.9	35.1	35.3	35.4	35.6	
220	29.9	30.1	30.2	30.4	30.5	30.6	30.8	31.0	31.2	31.4	31.5	31.7	31.8	31.9	32.1	32.2	32.4	32.5	32.6	
230	27.6	27.8	27.9	28.0	28.2	28.3	28.4	28.6	28.8	28.9	29.1	29.2	29.3	29.4	29.5	29.7	29.8	29.9	30.0	
240	25.6	25.7	25.9	26.0	26.1	26.2	26.3	26.4	26.6	26.7	26.9	27.0	27.1	27.2	27.3	27.4	27.5	27.6	27.7	
250	23.8	23.9	24.0	24.1	24.2	24.3	24.4	24.5	24.7	24.8	24.9	25.0	25.1	25.2	25.3	25.4	25.5	25.6	25.7	