

ENGINEERING SERVICES  
EXAMINATION-2016

Serial No.

56823

A-HUF-P-GEA

**ELECTRICAL ENGINEERING**

**Paper—I**  
**(Conventional)**

*Time Allowed : Three Hours*

*Maximum Marks : 200*

**INSTRUCTIONS**

*Please read each of the following instructions carefully before attempting questions :*

*There are SEVEN questions in the paper.*

*Candidates are required to attempt FIVE questions in all.*

*Question no. 1 is compulsory.*

*Out of the remaining SIX questions, attempt any FOUR questions.*

*The number of marks carried by a question/part is indicated against it.*

*Unless otherwise mentioned, symbols and notations have their usual standard meanings.*

*Assume suitable data, if necessary and indicate the same clearly.*

*Neat sketches are to be drawn to illustrate answers, wherever required.*

*All parts and sub-parts of a question are to be attempted together in the answer book.*

*Attempts of questions shall be counted in sequential order.*

*Unless struck off, attempt of a question shall be counted even if attempted partly.*

*Answers must be written in ENGLISH only.*

*Any page or portion of the page left blank in the answer book must be clearly struck off.*

1. Answer all of the following :

(a) Consider the following matrix A :

$$A = \begin{bmatrix} 0 & 1 \\ 0 & -2 \end{bmatrix}$$

Compute state transition matrix  $e^{At}$ . 5

(b) Calculate the equivalent resistance  $R_{ab}$  in the circuit given below.

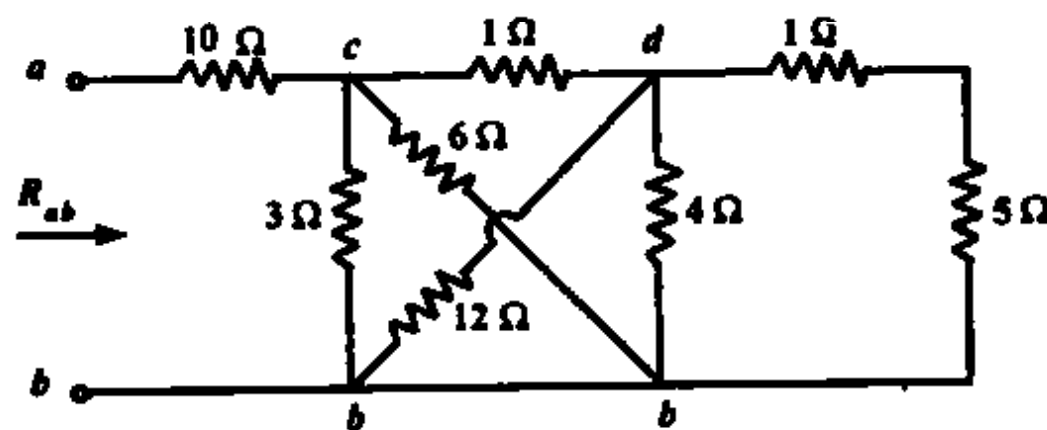

10

(c) Discuss in detail various factors affecting the resistivity of electrical materials. 5

(d) The electric field is given by  $E(r) = E_0 \cos(z/z_0) \exp(-r/r_0) \hat{r}$ , where  $z_0$  and  $r_0$  are constants. Check whether or not the electric field is conservative. If it is conservative find the potential, if it isn't suggest how it may be possible to find the electrostatic part of the electric field (if present) and the corresponding electrostatic potential  $V(r)$ . 10

(e) Write a note on classification of analog instruments. 10

10

2. (a) Obtain the transfer function of the mechanical system shown in Fig. 1(a) and show how that it is analogous to the system shown in Fig. 1(b) below.

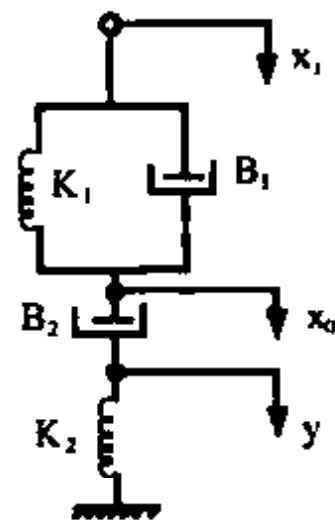

Fig. 1(a)

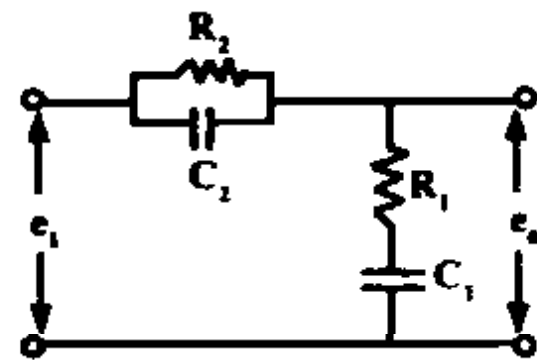
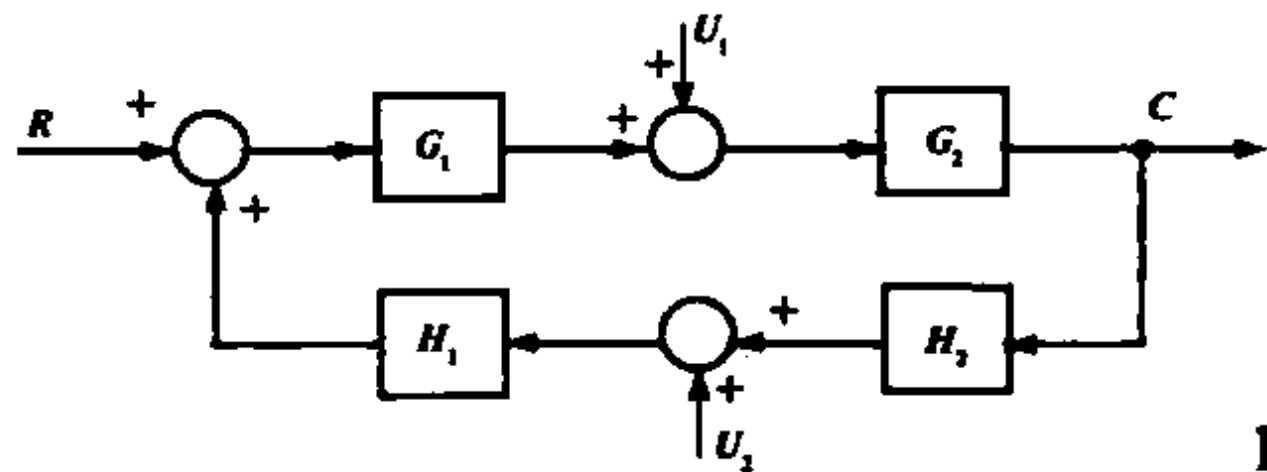

Fig. 1(b)

10

- (b) Determine the output  $C$  due to  $U_1$ ,  $U_2$  and  $R$  for block diagram shown below.



10

- (c) Consider a third order control system with the following characteristic equation

$$s^3 + 3408.3s^2 + 1,204,000s + 1.5 \times 10^7 K = 0$$

Determine the value of  $K$  for which at least one root will lie on the  $j\omega$  axis and none in the right half  $s$ -plane. 10

- (d) Explain in detail the different types of torques that are needed for satisfactory operation of any indicating instrument. 10

3. (a) The reflection and transmission of plane electromagnetic waves at plane dielectric boundaries normal to the direction of propagation can be treated by using transmission line theory in which the electric and magnetic field strengths are represented by the voltage and current and the wave impedance is represented by the characteristic impedance. Use this method to estimate the attenuation of an electromagnetic wave at 2 GHz as it passes through a brick wall 120 mm thick assuming that the relative permittivity is 4.0 and that losses can be neglected. 10
- (b) The coil of a PMMC instrument has 60 turns, on a former that is 18 mm wide, the effective length of the conductor being 25 mm. It moves in a uniform field of flux density 0.5 Tesla. The control spring constant is  $1.5 \times 10^{-6}$  Nm/degree. Calculate the current required to produce a deflection of 100 degree. 5
- (c) Explain in detail the principle of operation of Attraction-type Moving- Iron Instruments. 10

(d) A pure inductance of 150 mH is connected in parallel with a 40  $\mu$ F capacitor across a 50 V variable frequency supply as shown in the circuit below. Determine :

- (i) the resonant frequency of the circuit and
- (ii) the current circulating in the capacitor and inductance at resonance.

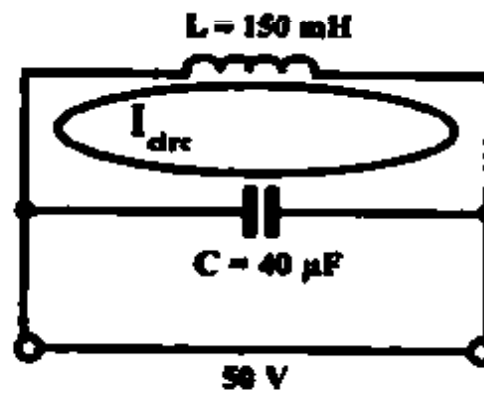

5

(e) Find currents and voltages in the circuit shown in figure below.

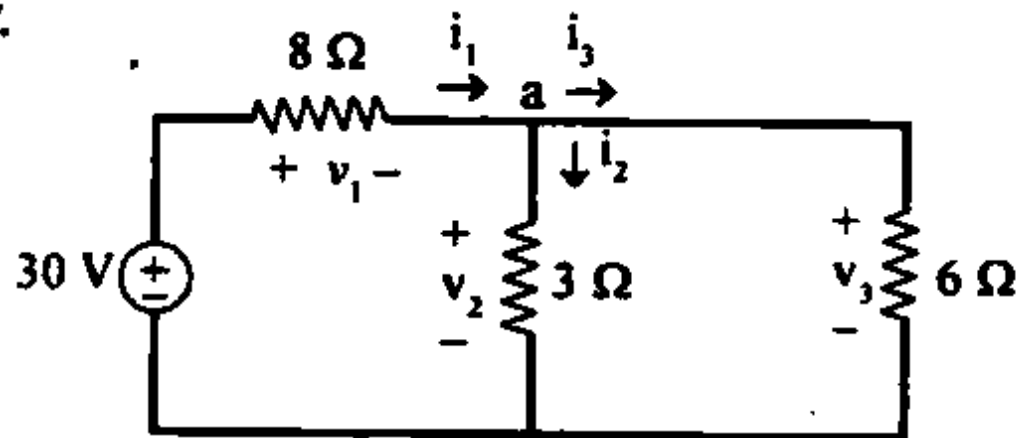

10

4. (a) Given the system shown below, find  $J$  and  $D$  to yield 20% overshoot and a settling time of 2 seconds for a step input of torque  $T(t)$ .

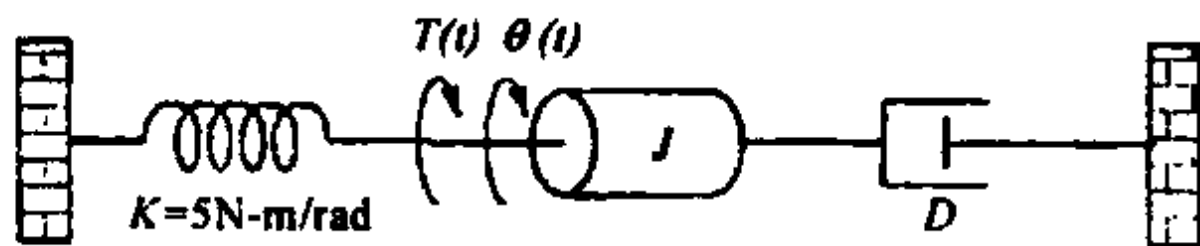

10

\*5\*

(Contd.)

(b) A coil of inductance  $100 \text{ mH}$  and resistance  $800 \Omega$  is connected in parallel with a variable capacitor across a  $12 \text{ V}$ ,  $5 \text{ kHz}$  supply. Determine for the condition when the supply current is a minimum :

(i) the capacitance of the capacitor,

(ii) the dynamic resistance,

(iii) the supply current, and

(iv) the Q-factor. 10

(c) Write a note on emission of electrons from metals. 10

(d) A moving-coil ammeter has a fixed shunt of  $0.02 \Omega$ . With a coil resistance of  $R = 1000 \Omega$  and a potential difference of  $500 \text{ mV}$  across it, full-scale deflection is obtained :

(1) To what shunted current does it correspond ?

(2) Calculate the value of  $R$  to give full-scale deflection when shunted current  $I$  is (i)  $10 \text{ A}$ , and (ii)  $75 \text{ A}$ .

(3) With what value of  $R$ , is 40% deflection obtained with  $I = 100 \text{ A}$  ? 10

5. (a) An air-spaced coaxial line has inner and outer conductors with radii  $a$  and  $b$  respectively as shown in

figure below. Show that the breakdown voltage of the line is highest when  $\ln(a/b) = 1$ .

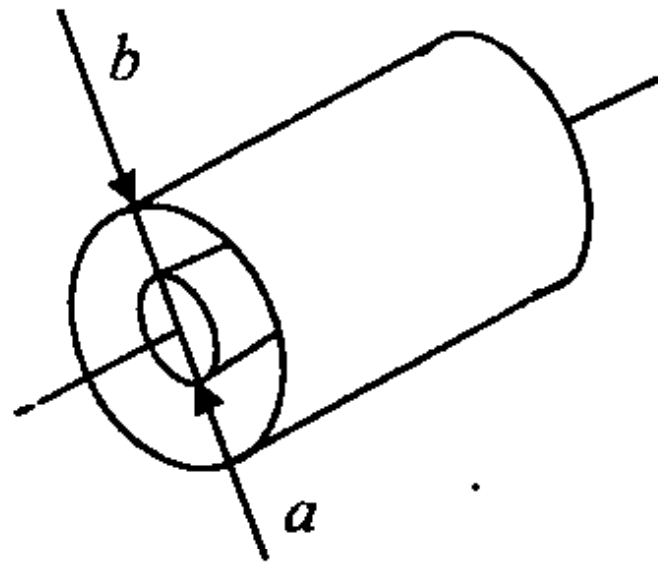

15

(b) Write a note on Hysteresis with typical hysteresis loop for ferromagnetic materials. 5

(c) A simple shunted ammeter using a basic meter movement with an internal resistance of  $1800 \Omega$  and a full-scale deflection current of  $100 \mu\text{A}$  is connected in a circuit and gives reading of  $3.5 \text{ mA}$  on its  $5 \text{ mA}$  scale. The reading is checked with a recently calibrated dc ammeter which gives a reading of  $4.1 \text{ mA}$ . The implication is that the ammeter has a faulty shunt on its  $5 \text{ mA}$  range. Calculate :

(1) the actual value of faulty shunt, and

(2) the current shunt for the  $5 \text{ mA}$  range.

10

(d) Find the input resistance  $R_{in}$ , of the circuit shown below.

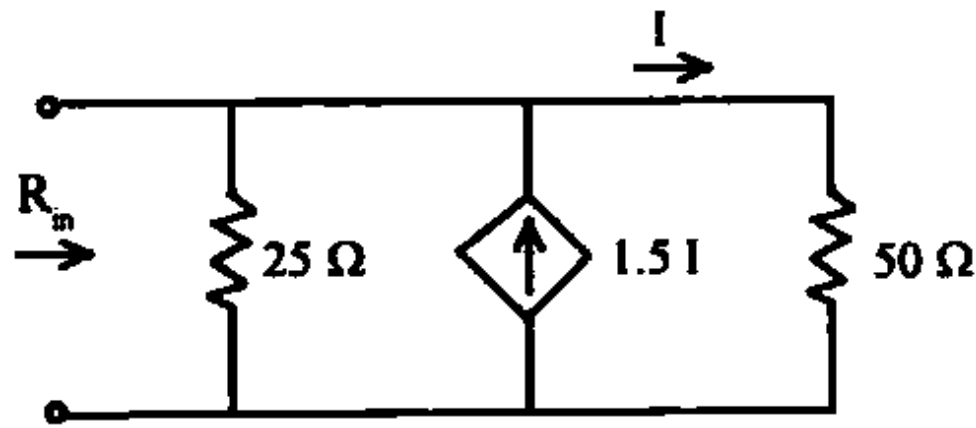

10

6. (a) Evaluate the transfer function of the block diagram shown below using block diagram reduction techniques.

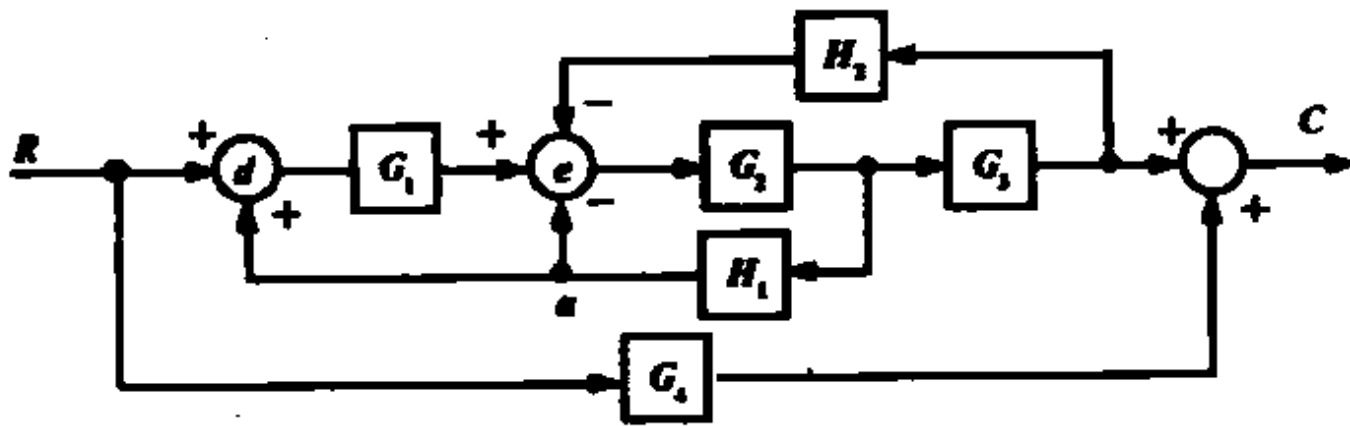

10

(b) Figure below shows a coaxial cable with two layers of dielectric material. Find an expression for the electric field at any point within the dielectric.

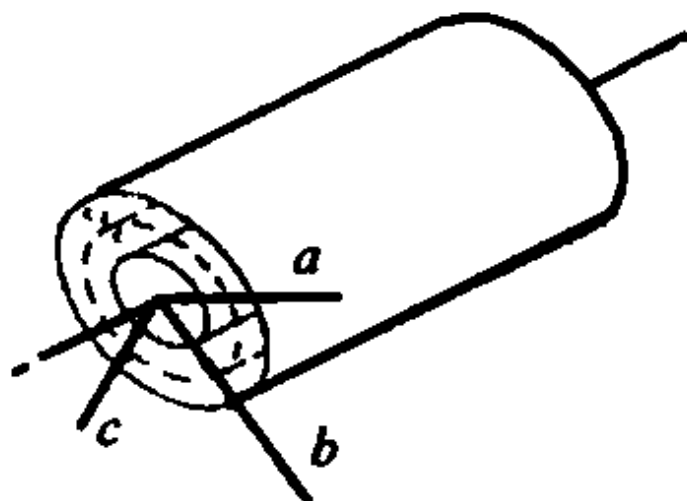

10



- (c) How much work must be done to assemble :
- (i) a physical dipole made of charge  $+q$  and charge  $-q$  separated by distance  $d$ ,
  - (ii) a physical quadrupole made up of four charges  $+q, -q, +q$  and  $-q$  on successive corners of a square of side  $d$ , and
  - (iii) a physical quadrupole made up of four charges  $-q, +q, +q$  and  $-q$  equally spaced apart by distance  $d$  on a straight line (see diagram below).

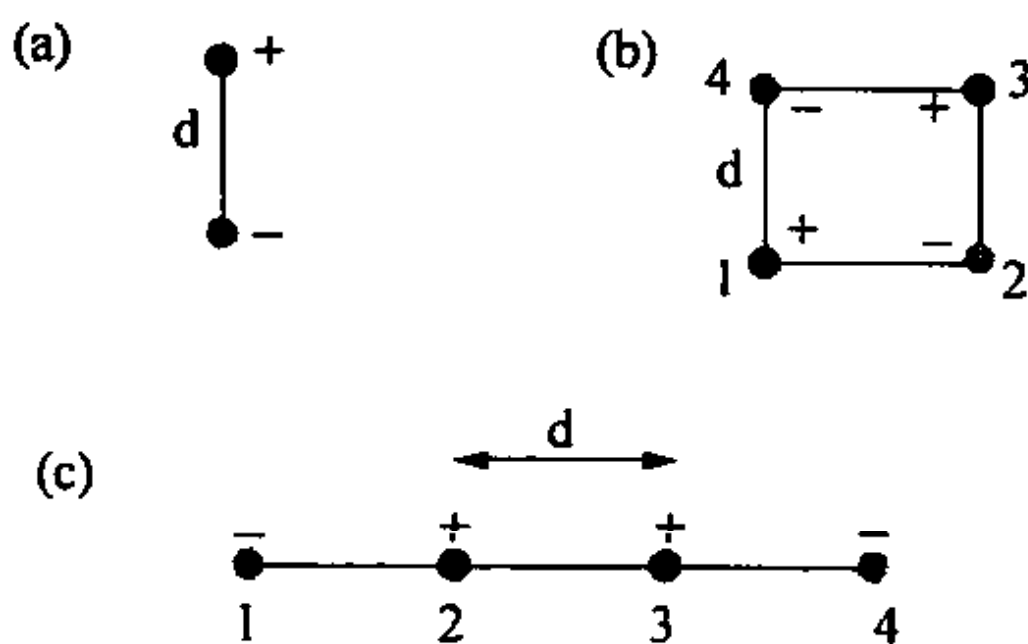

10

- (d) Compare the properties of diamagnetism, paramagnetism and ferromagnetism. 10

7. (a) Write a note on integrating-type DVM (voltage to frequency conversion). 10
- (b) The winding of an electromagnet has an inductance of 3 H and a resistance of  $15 \Omega$ . When it is connected to a 120 V, d.c. supply, calculate :
- (i) the steady-state value of current flowing in the winding,
  - (ii) the time constant of the circuit,
  - (iii) the value of the induced e.m.f. after 0.1 s,
  - (iv) the time for the current to rise to 85% of its final value, and
  - (v) the value of the current after 0.3 s. 10
- (c) Use mesh analysis to find the currents marked in the circuit shown below.

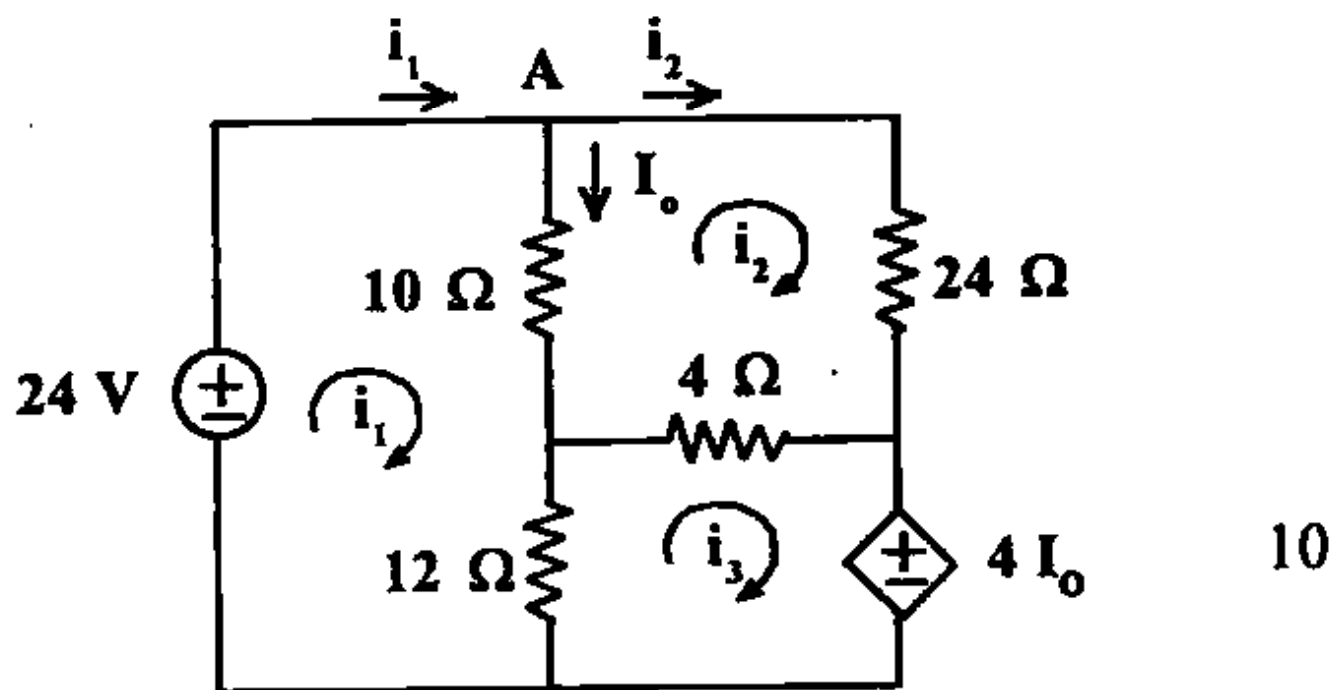

- (d) For the circuit shown in figure below, let  $R_1 = R_2$ ,  $R_3 * C = 1/10$ . Find the step response of the filter.

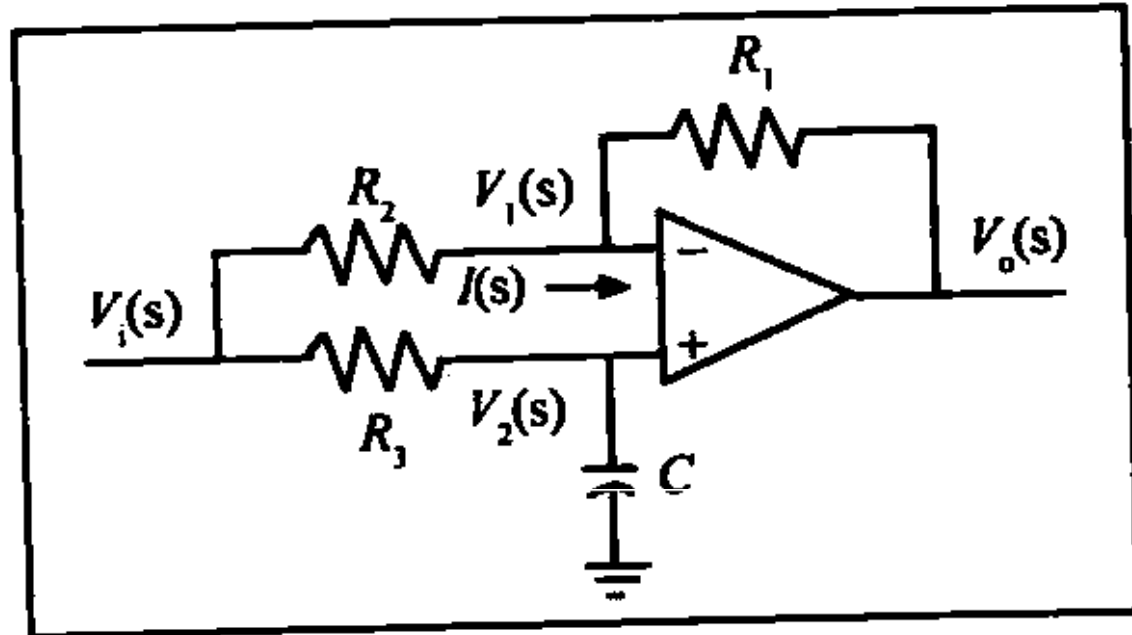

10

