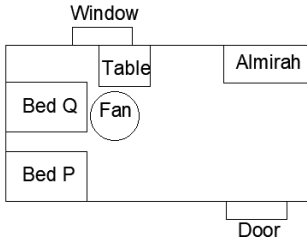
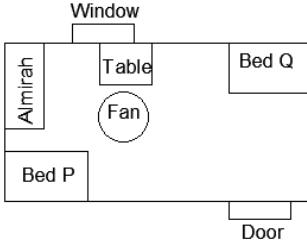
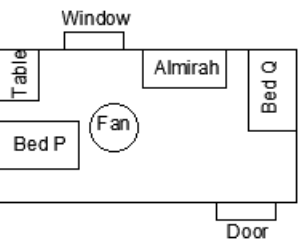
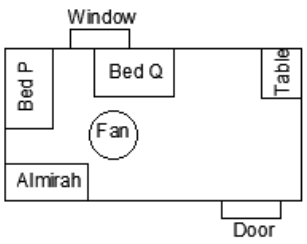

General Aptitude (GA)

Q.1 – Q.5 Carry ONE mark Each

Q.1	If '→' denotes increasing order of intensity, then the meaning of the words [talk → shout → scream] is analogous to [please → _____ → pander]. Which one of the given options is appropriate to fill the blank?
(A)	flatter
(B)	flutter
(C)	fritter
(D)	frizzle

<p>Q.2</p>	<p>P and Q have been allotted a hostel room with two beds, a study table, and an almirah. P is an avid bird-watcher and wants to sit at the table and watch birds outside the window. Q does not mind that as long as his bed is close to the ceiling fan.</p> <p>Which one of the following arrangements suits them the most?</p>
<p>(A)</p>	
<p>(B)</p>	
<p>(C)</p>	
<p>(D)</p>	

Q.3	<p>The decimal number system uses the characters 0, 1, 2, ..., 8, 9, and the octal number system uses the characters 0, 1, 2, ..., 6, 7.</p> <p>For example, the decimal number 12 ($= 1 \times 10^1 + 2 \times 10^0$) is expressed as 14 ($= 1 \times 8^1 + 4 \times 8^0$) in the octal number system.</p> <p>The decimal number 108 in the octal number system is</p>
(A)	168
(B)	108
(C)	150
(D)	154
Q.4	<p>A shopkeeper buys shirts from a producer and sells them at 20% profit. A customer has to pay ₹3,186.00 including 18% taxes, per shirt. At what price did the shopkeeper buy each shirt from the producer?</p>
(A)	₹2,500.00
(B)	₹1,975.40
(C)	₹2,250.00
(D)	₹2,548.80

Q.5	If, for non-zero real variables x, y , and real parameter $a > 1$, $x : y = (a + 1) : (a - 1),$ then, the ratio $(x^2 - y^2) : (x^2 + y^2)$ is
(A)	$2a : (a^2 + 1)$
(B)	$a : (a^2 + 1)$
(C)	$2a : (a^2 - 1)$
(D)	$a : (a^2 - 1)$

Q.6 – Q.10 Carry TWO marks Each

Q.6	<p>In the given text, the blanks are numbered (i)–(iv). Select the best match for all the blanks.</p> <p>Following a row _____ (i) _____ the shopkeeper _____ (ii) _____ the price of a frying pan, the cook stood _____ (iii) _____ a row to withdraw cash _____ (iv) _____ the ATM booth.</p>
(A)	(i) with (ii) over (iii) at (iv) with
(B)	(i) at (ii) over (iii) over (iv) in
(C)	(i) with (ii) over (iii) in (iv) at
(D)	(i) over (ii) with (iii) over (iv) at

Q.7

In the following figure,

$$CD = 5 \text{ cm, } BE = 10 \text{ cm, } AE = 12 \text{ cm,}$$

$$\angle DAB = \angle DCB, \text{ and } \angle DAE = \angle DBC = 90^\circ$$

Points AFCD create a rhombus.

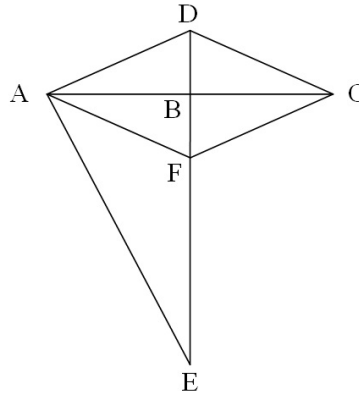

The length of BF (in cm) is

(A) 3

(B) 2

(C) 4

(D) 6

Q.8

The chart below shows the data of the number of cars bought by Millennials and Gen X people in a country from the year 2010 to 2020 as well as the yearly fuel consumption of the country (in Million liters).

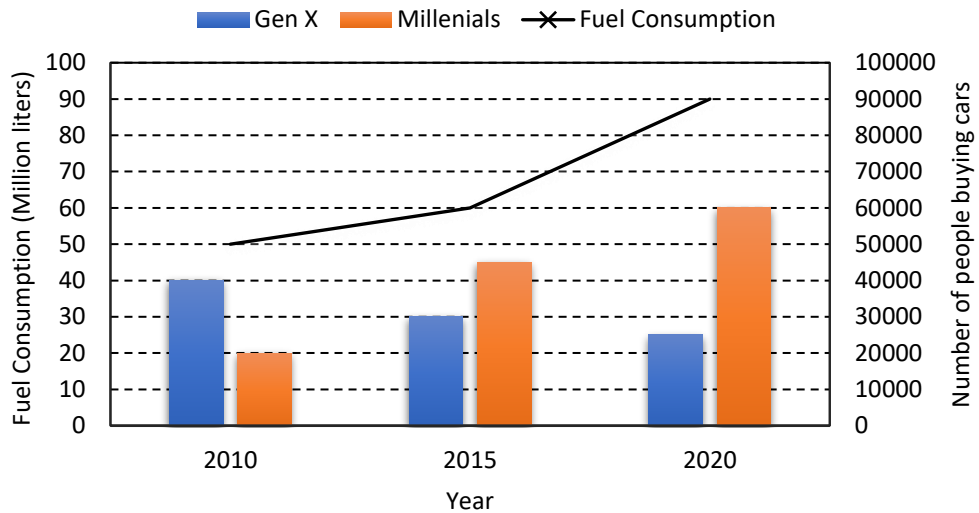

Considering the data presented in the chart, which one of the following options is true?

- (A) The percentage increase in fuel consumption from 2010 to 2015 is more than the percentage increase in fuel consumption from 2015 to 2020.
- (B) The increase in the number of Millennial car buyers from 2015 to 2020 is less than the decrease in the number of Gen X car buyers from 2010 to 2015.
- (C) The increase in the number of Millennial car buyers from 2010 to 2015 is more than the decrease in the number of Gen X car buyers from 2010 to 2015.
- (D) The decrease in the number of Gen X car buyers from 2015 to 2020 is more than the increase in the number of Millennial car buyers from 2010 to 2015.

Q.9

The assembly shown below has three teathed circular objects (Pinions) and two teathed flat objects (Racks), which are perfectly mating with each other. Pinions can only rotate clockwise or anti-clockwise staying at its own center. Racks can translate towards the left (\leftarrow) or the right (\rightarrow) direction.

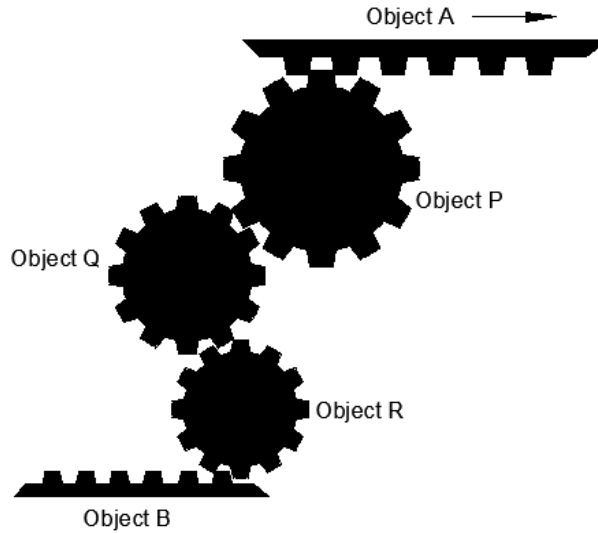

If the object A (Rack) is translating towards the right (\rightarrow) direction, the correct statement among the following is

- (A) Object B translates towards the right direction.
- (B) Object B translates towards the left direction.
- (C) Object R rotates in the anticlockwise direction.
- (D) Object Q rotates in the clockwise direction.

Q.10	A surveyor has to measure the horizontal distance from her position to a distant reference point C. Using her position as the center, a 200 m horizontal line segment is drawn with the two endpoints A and B. Points A, B, and C are not collinear. Each of the angles $\angle CAB$ and $\angle CBA$ are measured as 87.8° . The distance (in m) of the reference point C from her position is nearest to
(A)	2603
(B)	2606
(C)	2306
(D)	2063

Q.11 – Q.35 Carry ONE mark Each

Q.11	Which one of the following matrices has an inverse?
(A)	$\begin{bmatrix} 1 & 4 & 8 \\ 0 & 4 & 2 \\ 0.5 & 2 & 4 \end{bmatrix}$
(B)	$\begin{bmatrix} 1 & 2 & 3 \\ 2 & 4 & 6 \\ 3 & 2 & 9 \end{bmatrix}$
(C)	$\begin{bmatrix} 1 & 4 & 8 \\ 0 & 4 & 2 \\ 1 & 2 & 4 \end{bmatrix}$
(D)	$\begin{bmatrix} 1 & 4 & 8 \\ 0 & 4 & 2 \\ 3 & 12 & 24 \end{bmatrix}$

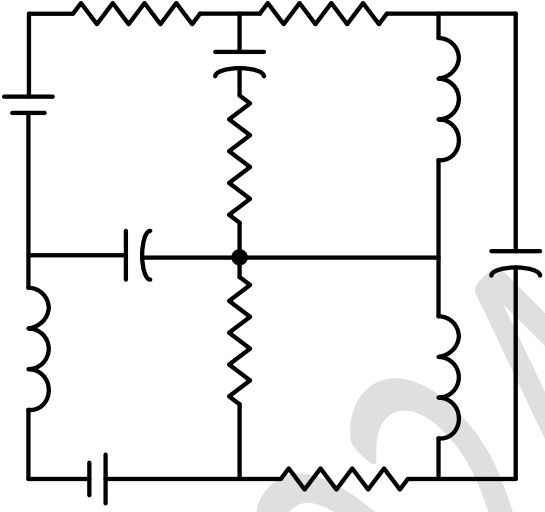
Q.12	The number of junctions in the circuit is
	 <p>The circuit diagram shows a network of components connected at nodes. The components include: a voltage source on the left vertical branch; a resistor on the top horizontal branch; a resistor in the middle vertical branch; a resistor on the bottom horizontal branch; a resistor on the right vertical branch; a capacitor on the left horizontal branch; a capacitor on the right horizontal branch; and two inductors, one on the far left vertical branch and one on the far right vertical branch. There are 9 nodes in total where two or more components meet.</p>
(A)	6
(B)	7
(C)	8
(D)	9

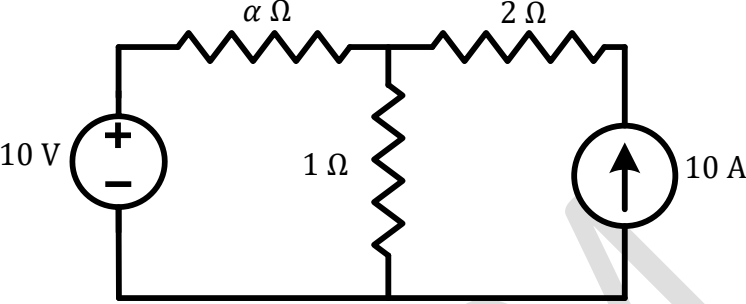
Q.13	All the elements in the circuit are ideal. The power delivered by the 10 V source in watts is
	
(A)	0
(B)	50
(C)	100
(D)	dependent on the value of α

Q.14 The circuit shown in the figure with the switch S open, is in steady state. After the switch S is closed, the time constant of the circuit in seconds is

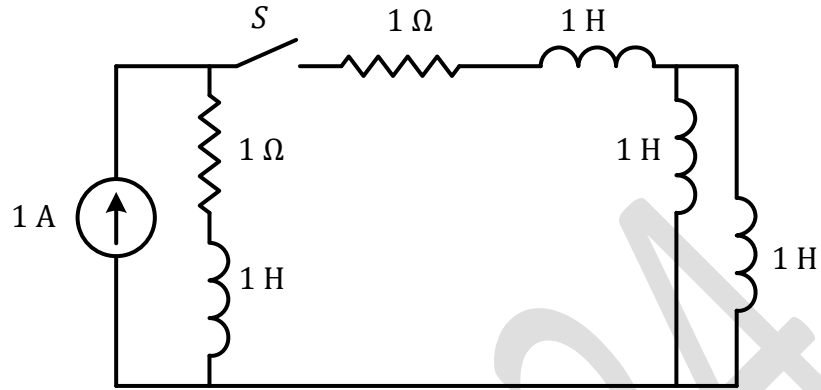

- | | |
|-----|------|
| (A) | 1.25 |
| (B) | 0 |
| (C) | 1 |
| (D) | 1.5 |

Q.15	Suppose signal $y(t)$ is obtained by the time-reversal of signal $x(t)$, i.e., $y(t) = x(-t)$, $-\infty < t < \infty$. Which one of the following options is always true for the convolution of $x(t)$ and $y(t)$?
(A)	It is an even signal.
(B)	It is an odd signal.
(C)	It is a causal signal.
(D)	It is an anti-causal signal.
Q.16	If $u(t)$ is the unit step function, then the region of convergence (ROC) of the Laplace transform of the signal $x(t) = e^{t^2} [u(t - 1) - u(t - 10)]$ is
(A)	$-\infty < \text{Re}(s) < \infty$
(B)	$\text{Re}(s) \geq 10$
(C)	$\text{Re}(s) \leq 1$
(D)	$1 \leq \text{Re}(s) \leq 10$

Q.17	A three phase, 50 Hz, 6 pole induction motor runs at 960 rpm. The stator copper loss, core loss, and the rotational loss of the motor can be neglected. The percentage efficiency of the motor is
(A)	92
(B)	94
(C)	96
(D)	98

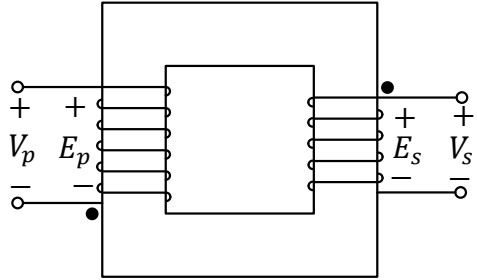
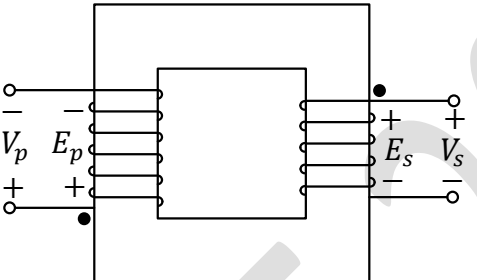
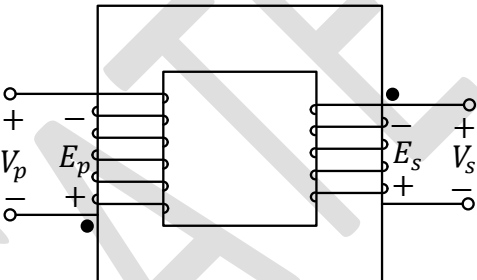
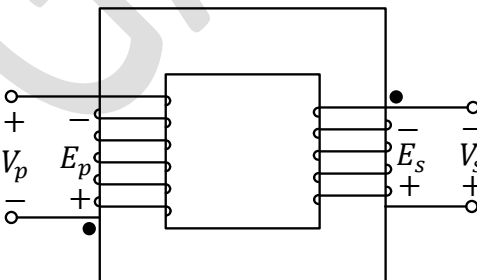
<p>Q.18</p>	<p>Which one of the following options represents possible voltage polarities in a single phase two winding transformer? Here, V_p is the applied primary voltage, E_p is the induced primary voltage, V_s is the open circuit secondary voltage, and E_s is the induced secondary voltage.</p>
<p>(A)</p>	
<p>(B)</p>	
<p>(C)</p>	
<p>(D)</p>	

Q.19

The figure shows the single line diagram of a 4-bus power network. Branches b_1 , b_2 , b_3 , and b_4 have impedances $4z$, z , $2z$, and $4z$ per-unit (pu), respectively, where $z = r + jx$, with $r > 0$ and $x > 0$. The current drawn from each load bus (marked as arrows) is equal to I pu, where $I \neq 0$. If the network is to operate with minimum loss, the branch that should be opened is

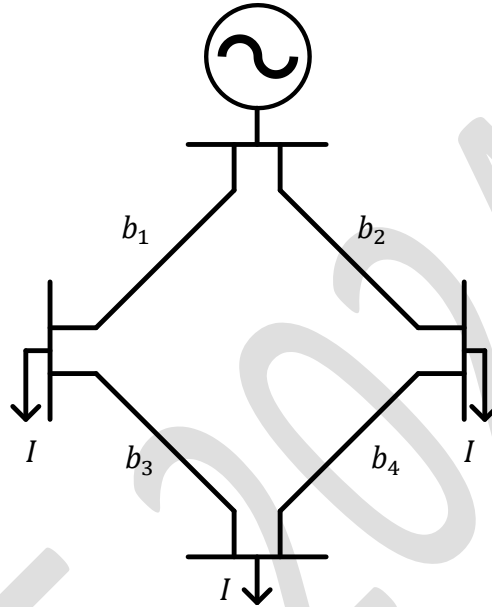

(A) b_1

(B) b_2

(C) b_3

(D) b_4

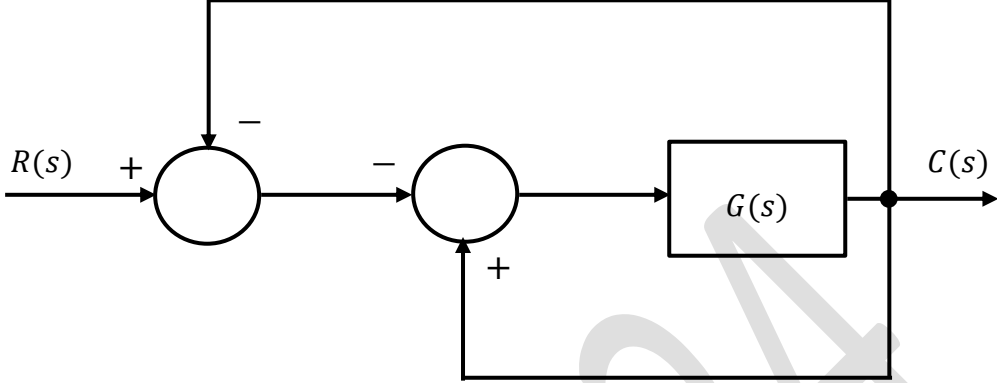
Q.20	For the block-diagram shown in the figure, the transfer function $\frac{C(s)}{R(s)}$ is
	
(A)	$\frac{G(s)}{1 + 2G(s)}$
(B)	$-\frac{G(s)}{1 + 2G(s)}$
(C)	$\frac{G(s)}{1 - 2G(s)}$
(D)	$-\frac{G(s)}{1 - 2G(s)}$

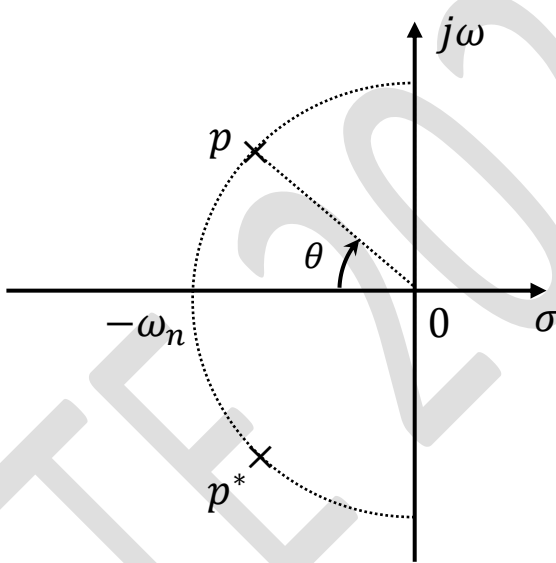
<p>Q.21</p>	<p>Consider the standard second-order system of the form $\frac{\omega_n^2}{s^2 + 2\zeta\omega_n s + \omega_n^2}$ with the poles p and p^* having negative real parts. The pole locations are also shown in the figure. Now consider two such second-order systems as defined below:</p> <p style="text-align: center;">System 1: $\omega_n = 3$ rad/sec and $\theta = 60^\circ$ System 2: $\omega_n = 1$ rad/sec and $\theta = 70^\circ$</p> <p>Which one of the following statements is correct?</p>
	
(A)	Settling time of System 1 is more than that of System 2.
(B)	Settling time of System 2 is more than that of System 1.
(C)	Settling times of both the systems are the same.
(D)	Settling time cannot be computed from the given information.

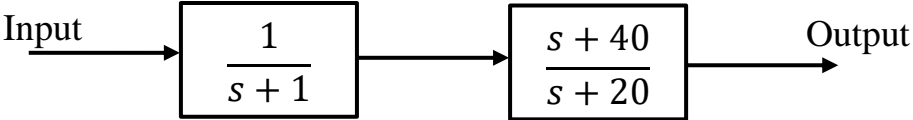
Q.22	<p>Consider the cascaded system as shown in the figure. Neglecting the faster component of the transient response, which one of the following options is a first-order pole-only approximation such that the steady-state values of the unit step responses of the original and the approximated systems are same?</p>
	
(A)	$\frac{1}{s+1}$
(B)	$\frac{2}{s+1}$
(C)	$\frac{1}{s+20}$
(D)	$\frac{2}{s+20}$

Q.23	The table lists two instrument transformers and their features:	
	Instrument Transformers	Features
		P) Primary is connected in parallel to the grid
	X) Current Transformer (CT)	Q) Open circuited secondary is not desirable
	Y) Potential Transformer (PT)	R) Primary current is the line current
		S) Secondary burden affects the primary current
	The correct matching of the two columns is	
(A)	X matches with P and Q; Y matches with R and S.	
(B)	X matches with P and R; Y matches with Q and S.	
(C)	X matches with Q and R; Y matches with P and S.	
(D)	X matches with Q and S; Y matches with P and R.	

Q.24	Simplified form of the Boolean function $F(P, Q, R, S) = \bar{P}\bar{Q} + \bar{P}QS + P\bar{Q}\bar{R}\bar{S} + P\bar{Q}R\bar{S}$ is
(A)	$\bar{P}S + \bar{Q}\bar{S}$
(B)	$\bar{P}\bar{Q} + \bar{Q}\bar{S}$
(C)	$\bar{P}Q + R\bar{S}$
(D)	$P\bar{S} + Q\bar{R}$

Q.25 In the circuit, the present value of Z is 1. Neglecting the delay in the combinatorial circuit, the values of S and Z , respectively, after the application of the clock will be

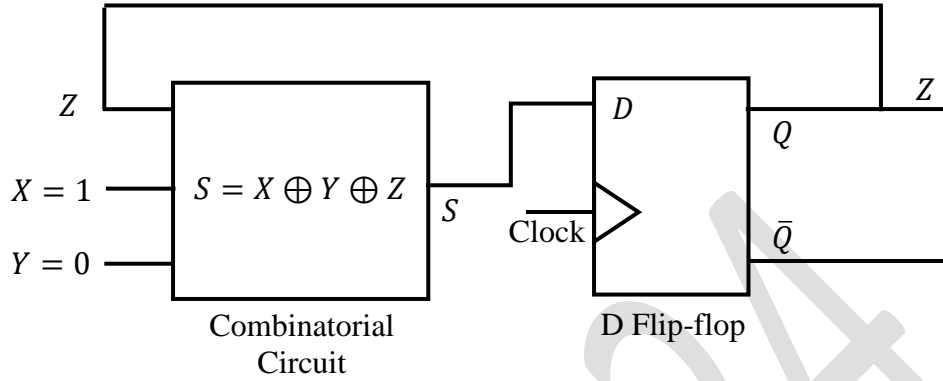

- (A) $S = 0, Z = 0$
- (B) $S = 0, Z = 1$
- (C) $S = 1, Z = 0$
- (D) $S = 1, Z = 1$

Q.26	To obtain the Boolean function $F(X, Y) = X\bar{Y} + \bar{X}$, the inputs $PQRS$ in the figure should be
	<div style="text-align: center;"> <p>4:1 Multiplexer</p> <p>S_1 and S_0 are the select lines.</p> </div>
(A)	1010
(B)	1110
(C)	0110
(D)	0001

Q.27	If the following switching devices have similar power ratings, which one of them is the fastest?
(A)	SCR
(B)	GTO
(C)	IGBT
(D)	Power MOSFET
Q.28	A single-phase triac based AC voltage controller feeds a series RL load. The input AC supply is 230 V, 50 Hz. The values of R and L are 10 Ω and 18.37 mH, respectively. The minimum triggering angle of the triac to obtain controllable output voltage is
(A)	15°
(B)	30°
(C)	45°
(D)	60°

Q.29	Let X be a discrete random variable that is uniformly distributed over the set $\{-10, -9, \dots, 0, \dots, 9, 10\}$. Which of the following random variables is/are uniformly distributed?
(A)	X^2
(B)	X^3
(C)	$(X - 5)^2$
(D)	$(X + 10)^2$
Q.30	Which of the following complex functions is/are analytic on the complex plane?
(A)	$f(z) = j\text{Re}(z)$
(B)	$f(z) = \text{Im}(z)$
(C)	$f(z) = e^{ z }$
(D)	$f(z) = z^2 - z$

Q.31	Consider the complex function $f(z) = \cos z + e^{z^2}$. The coefficient of z^5 in the Taylor series expansion of $f(z)$ about the origin is _____ (rounded off to 1 decimal place).
Q.32	The sum of the eigenvalues of the matrix $A = \begin{bmatrix} 1 & 2 \\ 3 & 4 \end{bmatrix}^2$ is _____ (rounded off to the nearest integer).
Q.33	Let $X(\omega)$ be the Fourier transform of the signal $x(t) = e^{-t^4} \cos t, \quad -\infty < t < \infty.$ The value of the derivative of $X(\omega)$ at $\omega = 0$ is _____ (rounded off to 1 decimal place).

Q.34

The incremental cost curves of two generators (Gen A and Gen B) in a plant supplying a common load are shown in the figure. If the incremental cost of supplying the common load is Rs. 7400 per MWh, then the common load in MW is _____ (rounded off to the nearest integer).

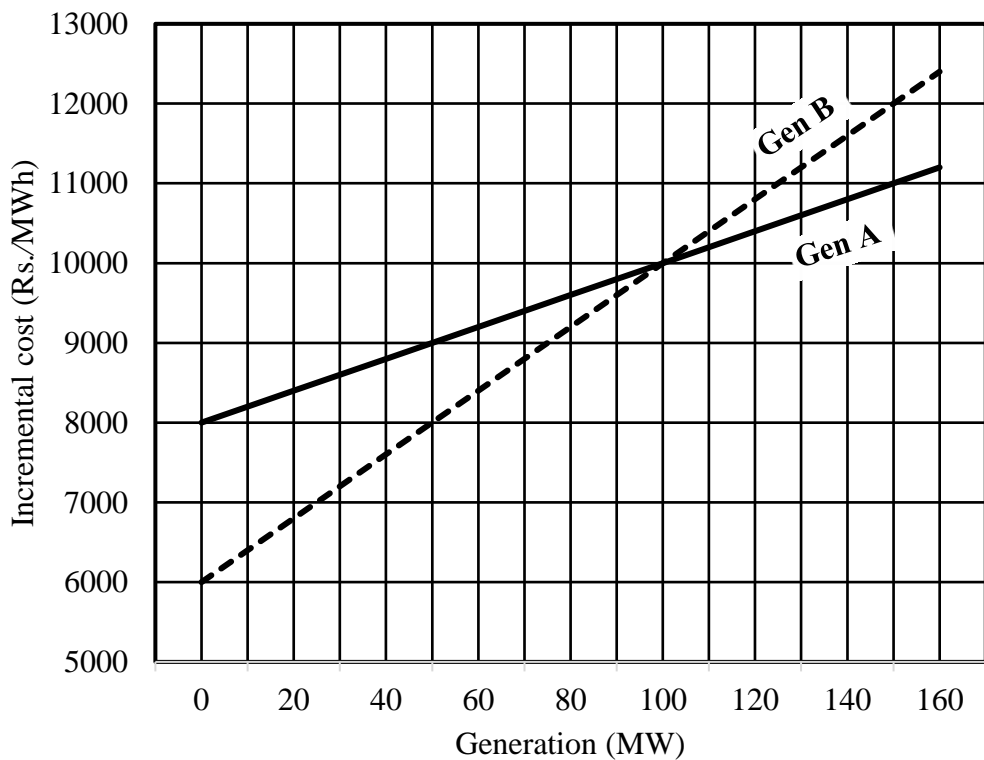
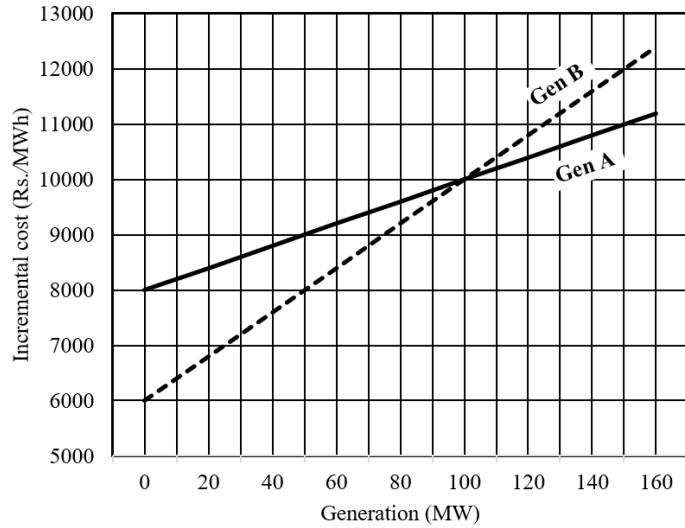

Q.35

A forced commutated thyristorized step-down chopper is shown in the figure. Neglect the ON-state drop across the power devices. Assume that the capacitor is initially charged to 50 V with the polarity shown in the figure. The load current (I_L) can be assumed to be constant at 10 A. Initially, Th_M is ON and Th_A is OFF. The turn-off time available to Th_M in microseconds, when Th_A is triggered, is _____ (rounded off to the nearest integer).

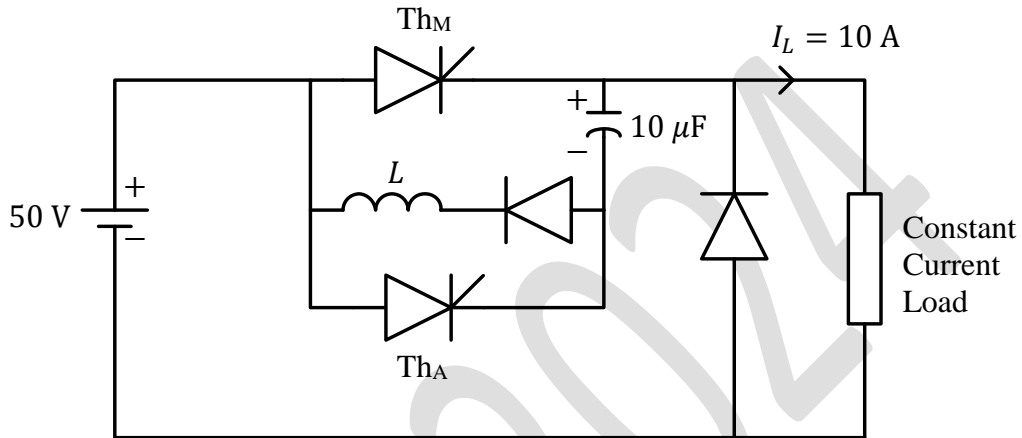

Q.36 – Q.65 Carry TWO marks Each

Q.36	Consider a vector $\vec{u} = 2\hat{x} + \hat{y} + 2\hat{z}$, where $\hat{x}, \hat{y}, \hat{z}$ represent unit vectors along the coordinate axes x, y, z respectively. The directional derivative of the function $f(x, y, z) = 2 \ln(xy) + \ln(yz) + 3 \ln(xz)$ at the point $(x, y, z) = (1, 1, 1)$ in the direction of \vec{u} is
(A)	0
(B)	$\frac{7}{5\sqrt{2}}$
(C)	7
(D)	21

Q.37	The input $x(t)$ and the output $y(t)$ of a system are related as $y(t) = e^{-t} \int_{-\infty}^t e^{\tau} x(\tau) d\tau, \quad -\infty < t < \infty.$ The system is
(A)	nonlinear.
(B)	linear and time-invariant.
(C)	linear but not time-invariant.
(D)	noncausal.

Q.38	<p>Consider the discrete-time systems T_1 and T_2 defined as follows:</p> $\{T_1x\}[n] = x[0] + x[1] + \dots + x[n]$ $\{T_2x\}[n] = x[0] + \frac{1}{2}x[1] + \dots + \frac{1}{2^n}x[n]$ <p>Which one of the following statements is true?</p>
(A)	T_1 and T_2 are BIBO stable.
(B)	T_1 and T_2 are not BIBO stable.
(C)	T_1 is BIBO stable but T_2 is not BIBO stable.
(D)	T_1 is not BIBO stable but T_2 is BIBO stable.

Q.39	If the Z-transform of a finite-duration discrete-time signal $x[n]$ is $X(z)$, then the Z-transform of the signal $y[n] = x[2n]$ is
(A)	$Y(z) = X(z^2)$
(B)	$Y(z) = \frac{1}{2} [X(z^{-1/2}) + X(-z^{-1/2})]$
(C)	$Y(z) = \frac{1}{2} [X(z^{1/2}) + X(-z^{1/2})]$
(D)	$Y(z) = \frac{1}{2} [X(z^2) + X(-z^2)]$
Q.40	A 3-phase, 11 kV, 10 MVA synchronous generator is connected to an inductive load of power factor $(\sqrt{3}/2)$ via a lossless line with a per-phase inductive reactance of 5Ω . The per-phase synchronous reactance of the generator is 30Ω with negligible armature resistance. If the generator is producing the rated current at the rated voltage, then the power factor at the terminal of the generator is
(A)	0.63 lagging.
(B)	0.87 lagging.
(C)	0.63 leading.
(D)	0.87 leading.

Q.41

For the three-bus lossless power network shown in the figure, the voltage magnitudes at all the buses are equal to 1 per unit (pu), and the differences of the voltage phase angles are very small. The line reactances are marked in the figure, where α , β , γ , and x are strictly positive. The bus injections P_1 and P_2 are in pu. If $P_1 = mP_2$, where $m > 0$, and the real power flow from bus 1 to bus 2 is 0 pu, then which one of the following options is correct?

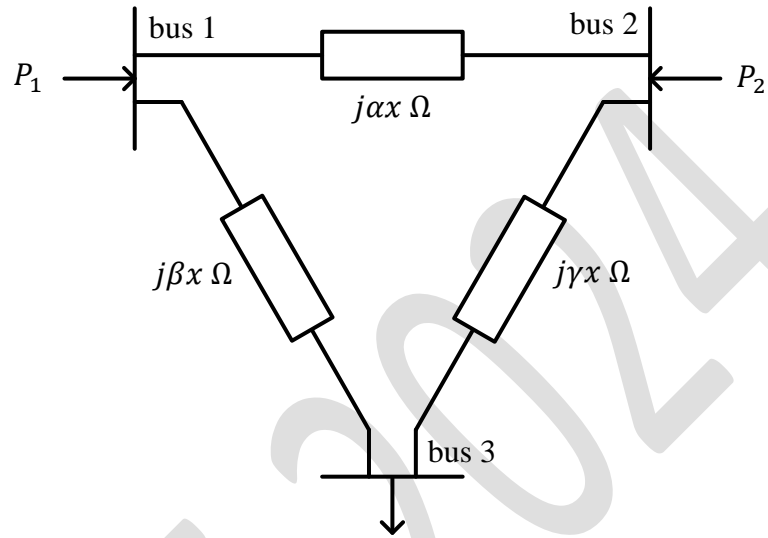

(A) $\gamma = m\beta$

(B) $\beta = m\gamma$

(C) $\alpha = m\gamma$

(D) $\alpha = m\beta$

Q.42

A BJT biasing circuit is shown in the figure, where $V_{BE} = 0.7 \text{ V}$ and $\beta = 100$. The Quiescent Point values of V_{CE} and I_C are respectively

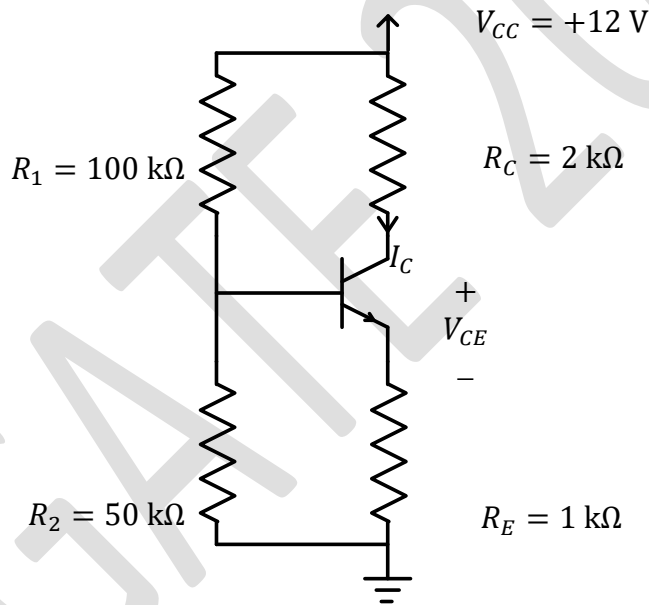
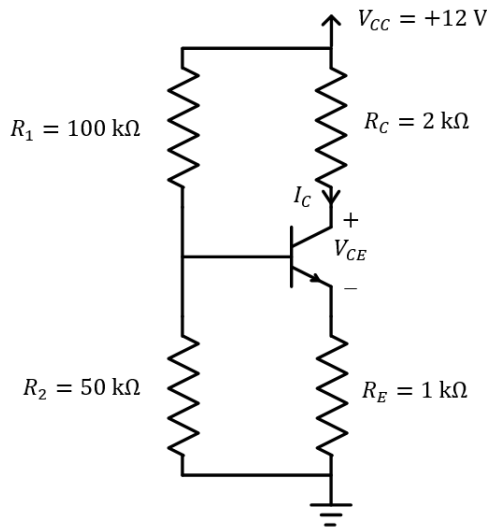

(A) 4.6 V and 2.46 mA

(B) 3.5 V and 2.46 mA

(C) 2.61 V and 3.13 mA

(D) 4.6 V and 3.13 mA

Q.43	Let $f(t)$ be a real-valued function whose second derivative is positive for $-\infty < t < \infty$. Which of the following statements is/are always true?
(A)	$f(t)$ has at least one local minimum.
(B)	$f(t)$ cannot have two distinct local minima.
(C)	$f(t)$ has at least one local maximum.
(D)	The minimum value of $f(t)$ cannot be negative.
Q.44	Consider the function $f(t) = (\max(0, t))^2$ for $-\infty < t < \infty$, where $\max(a, b)$ denotes the maximum of a and b . Which of the following statements is/are true?
(A)	$f(t)$ is not differentiable.
(B)	$f(t)$ is differentiable and its derivative is continuous.
(C)	$f(t)$ is differentiable but its derivative is not continuous.
(D)	$f(t)$ and its derivative are differentiable.

Q.45	Which of the following differential equations is/are nonlinear?
(A)	$t x(t) + \frac{dx(t)}{dt} = t^2 e^t, \quad x(0) = 0$
(B)	$\frac{1}{2} e^t + x(t) \frac{dx(t)}{dt} = 0, \quad x(0) = 0$
(C)	$x(t) \cos t - \frac{dx(t)}{dt} \sin t = 1, \quad x(0) = 0$
(D)	$x(t) + e^{\left(\frac{dx(t)}{dt}\right)} = 1, \quad x(0) = 0$
Q.46	For a two-phase network, the phase voltages V_p and V_q are to be expressed in terms of sequence voltages V_α and V_β as $\begin{bmatrix} V_p \\ V_q \end{bmatrix} = \mathbf{S} \begin{bmatrix} V_\alpha \\ V_\beta \end{bmatrix}$. The possible option(s) for matrix \mathbf{S} is/are
(A)	$\begin{bmatrix} 1 & 1 \\ 1 & -1 \end{bmatrix}$
(B)	$\begin{bmatrix} 1 & 1 \\ 1 & 1 \end{bmatrix}$
(C)	$\begin{bmatrix} 1 & 1 \\ 1 & 0 \end{bmatrix}$
(D)	$\begin{bmatrix} -1 & 1 \\ 1 & 1 \end{bmatrix}$

Q.47	Which of the following options is/are correct for the Automatic Generation Control (AGC) and Automatic Voltage Regulator (AVR) installed with synchronous generators?
(A)	AGC response has a local effect on frequency while AVR response has a global effect on voltage.
(B)	AGC response has a global effect on frequency while AVR response has a local effect on voltage.
(C)	AGC regulates the field current of the synchronous generator while AVR regulates the generator's mechanical power input.
(D)	AGC regulates the generator's mechanical power input while AVR regulates the field current of the synchronous generator.

Q.48 Two passive two-port networks **P** and **Q** are connected as shown in the figure. The impedance matrix of network **P** is $Z_P = \begin{bmatrix} 40 \Omega & 60 \Omega \\ 80 \Omega & 100 \Omega \end{bmatrix}$. The admittance matrix of network **Q** is $Y_Q = \begin{bmatrix} 5 \text{ S} & -2.5 \text{ S} \\ -2.5 \text{ S} & 1 \text{ S} \end{bmatrix}$. Let the ABCD matrix of the two-port network **R** in the figure be $\begin{bmatrix} \alpha & \beta \\ \gamma & \delta \end{bmatrix}$. The value of β in Ω is _____ (rounded off to 2 decimal places).

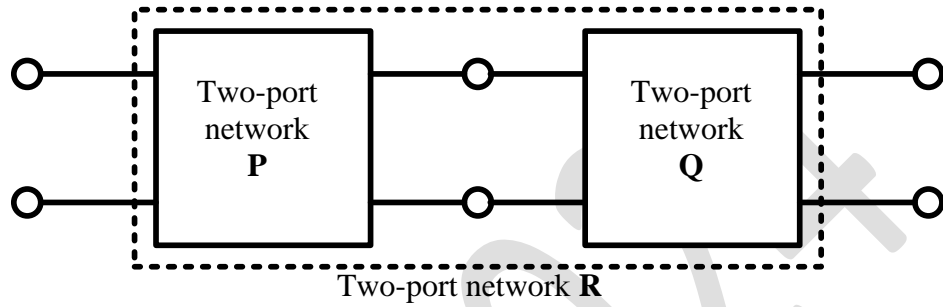

Q.49 For the circuit shown in the figure, the source frequency is 5000 rad/sec. The mutual inductance between the magnetically coupled inductors is 5 mH with their self inductances being 125 mH and 1 mH. The Thevenin's impedance, Z_{th} , between the terminals *P* and *Q* in Ω is _____ (rounded off to 2 decimal places).

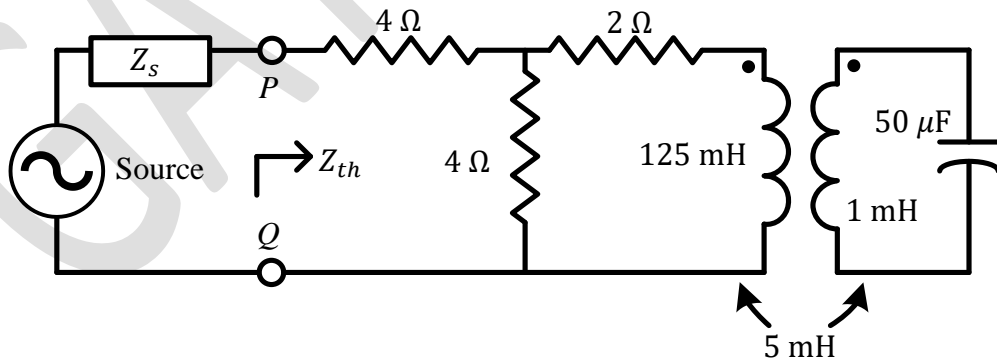

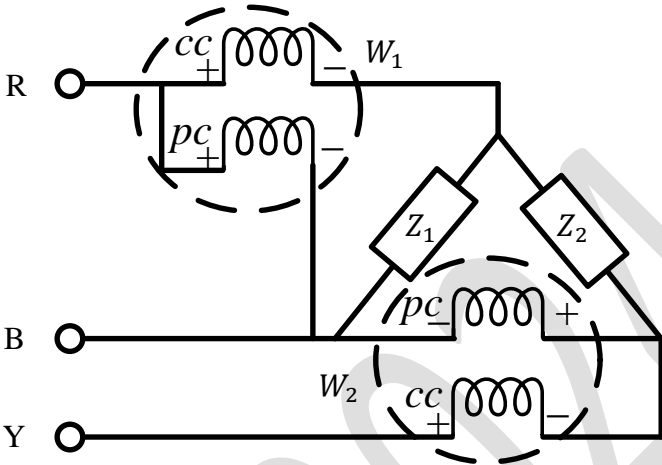
<p>Q.50</p>	<p>In the circuit shown, $Z_1 = 50\angle -90^\circ \Omega$ and $Z_2 = 200\angle -30^\circ \Omega$. It is supplied by a three phase 400 V source with the phase sequence being R-Y-B. Assume the watt meters W_1 and W_2 to be ideal. The magnitude of the difference between the readings of W_1 and W_2 in watts is _____ (rounded off to 2 decimal places).</p>
	
<p>Q.51</p>	<p>In the (x, y, z) coordinate system, three point-charges Q, Q, and αQ are located in free space at $(-1, 0, 0)$, $(1, 0, 0)$, and $(0, -1, 0)$, respectively. The value of α for the electric field to be zero at $(0, 0.5, 0)$ is _____ (rounded off to 1 decimal place).</p>
<p>Q.52</p>	<p>The given equation represents a magnetic field strength $\vec{H}(r, \theta, \phi)$ in the spherical coordinate system, in free space. Here, \hat{r} and $\hat{\theta}$ represent the unit vectors along r and θ, respectively. The value of P in the equation should be _____ (rounded off to the nearest integer).</p>
	$\vec{H}(r, \theta, \phi) = \frac{1}{r^3} (\hat{r}P \cos \theta + \hat{\theta} \sin \theta)$
<p>Q.53</p>	<p>If the energy of a continuous-time signal $x(t)$ is E and the energy of the signal $2x(2t - 1)$ is cE, then c is _____ (rounded off to 1 decimal place).</p>

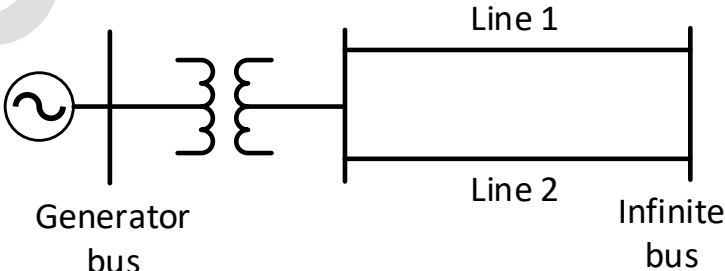
<p>Q.54</p>	<p>A 3-phase star connected slip ring induction motor has the following parameters referred to the stator:</p> $R_s = 3 \Omega, X_s = 2 \Omega, X_r' = 2 \Omega, R_r' = 2.5 \Omega$ <p>The per phase stator to rotor effective turns ratio is 3:1. The rotor winding is also star connected. The magnetizing reactance and core loss of the motor can be neglected. To have maximum torque at starting, the value of the extra resistance in ohms (referred to the rotor side) to be connected in series with each phase of the rotor winding is _____ (rounded off to 2 decimal places).</p>
<p>Q.55</p>	<p>A 5 kW, 220 V DC shunt motor has 0.5 Ω armature resistance including brushes. The motor draws a no-load current of 3 A. The field current is constant at 1 A. Assuming that the core and rotational losses are constant and independent of the load, the current (in amperes) drawn by the motor while delivering the rated load, for the best possible efficiency, is _____ (rounded off to 2 decimal places).</p>
<p>Q.56</p>	<p>The single line diagram of a lossless system is shown in the figure. The system is operating in steady-state at a stable equilibrium point with the power output of the generator being $P_{max} \sin \delta$, where δ is the load angle and the mechanical power input is $0.5P_{max}$. A fault occurs on line 2 such that the power output of the generator is less than $0.5P_{max}$ during the fault. After the fault is cleared by opening line 2, the power output of the generator is $\{P_{max}/\sqrt{2}\} \sin \delta$. If the critical fault clearing angle is $\pi/2$ radians, the accelerating area on the power angle curve is _____ times P_{max} (rounded off to 2 decimal places).</p>
	

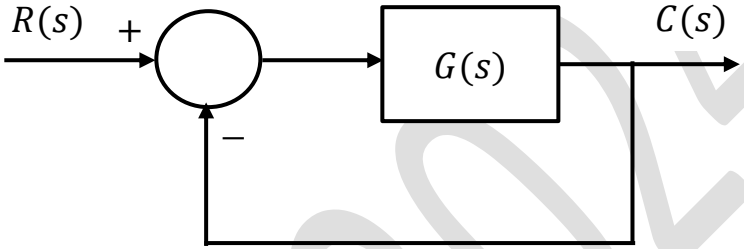
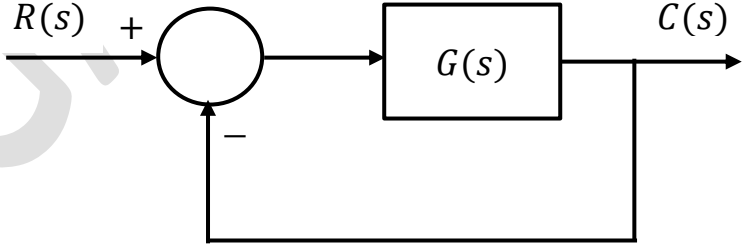
<p>Q.57</p>	<p>Consider the closed-loop system shown in the figure with</p> $G(s) = \frac{K(s^2 - 2s + 2)}{(s^2 + 2s + 5)}$ <p>The root locus for the closed-loop system is to be drawn for $0 \leq K < \infty$. The angle of departure (between 0° and 360°) of the root locus branch drawn from the pole $(-1 + j2)$, in degrees, is _____ (rounded off to the nearest integer).</p>
	
<p>Q.58</p>	<p>Consider the stable closed-loop system shown in the figure. The asymptotic Bode magnitude plot of $G(s)$ has a constant slope of -20 dB/decade at least till 100 rad/sec with the gain crossover frequency being 10 rad/sec. The asymptotic Bode phase plot remains constant at -90° at least till $\omega = 10$ rad/sec. The steady-state error of the closed-loop system for a unit ramp input is _____ (rounded off to 2 decimal places).</p>
	

Q.59

Consider the stable closed-loop system shown in the figure. The magnitude and phase values of the frequency response of $G(s)$ are given in the table. The value of the gain $K_I (> 0)$ for a 50° phase margin is _____ (rounded off to 2 decimal places).

ω in rad/sec	Magnitude in dB	Phase in degrees
0.5	-7	-40
1.0	-10	-80
2.0	-18	-130
10.0	-40	-200

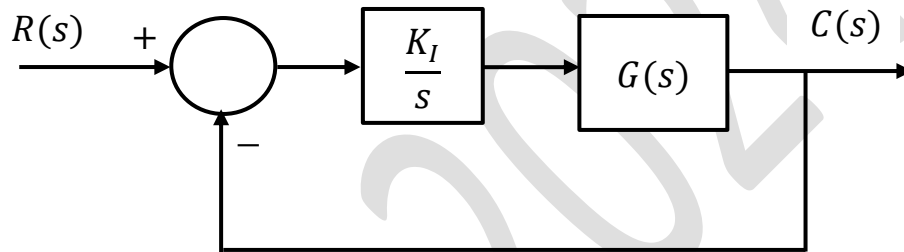

Q.60

In the given circuit, the diodes are ideal. The current I through the diode $D1$ in milliamperes is _____ (rounded off to two decimal places).

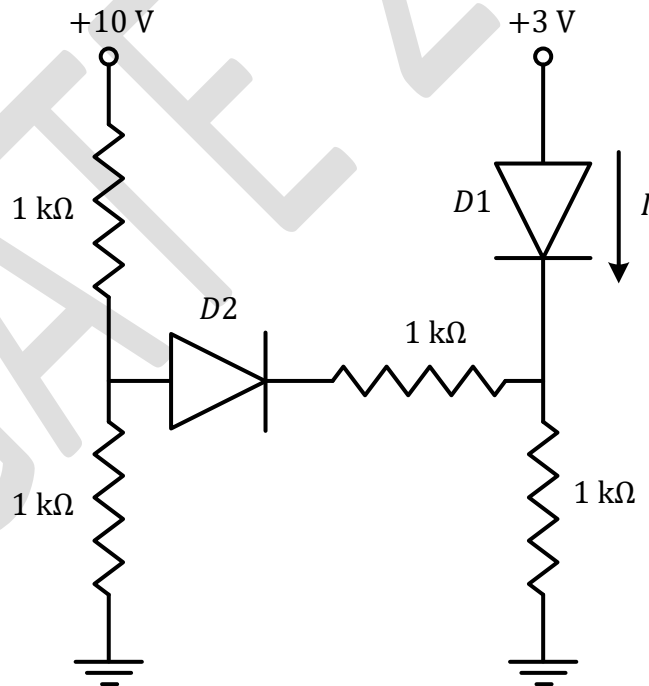
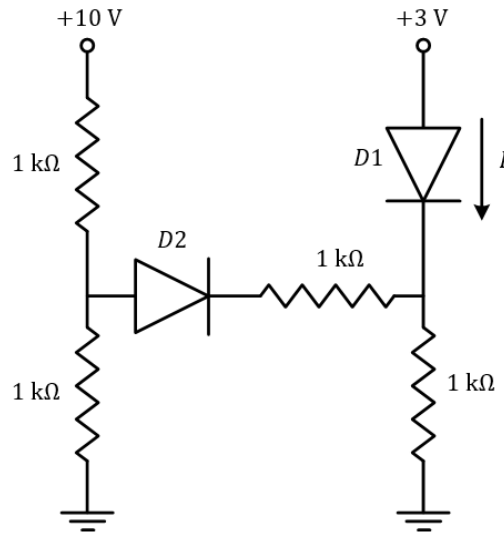

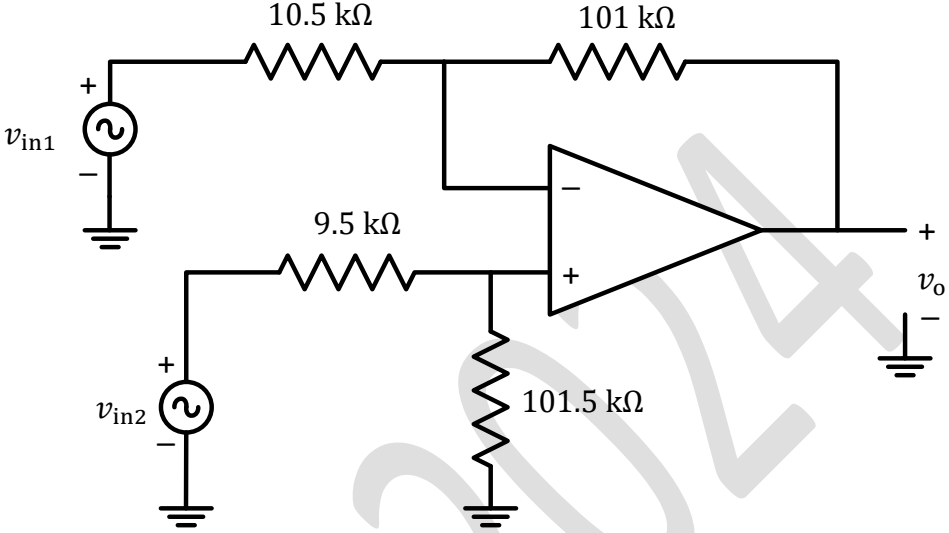
<p>Q.61</p>	<p>A difference amplifier is shown in the figure. Assume the op-amp to be ideal. The CMRR (in dB) of the difference amplifier is _____ (rounded off to 2 decimal places).</p>
	
<p>Q.62</p>	<p>A single-phase half-controlled bridge converter supplies an inductive load with ripple free load current. The triggering angle of the converter is 60°. The ratio of the rms value of the fundamental component of the input current to the rms value of the total input current of the bridge is _____ (rounded off to 3 decimal places).</p>
<p>Q.63</p>	<p>A single-phase full bridge voltage source inverter (VSI) feeds a purely inductive load. The inverter output voltage is a square wave in 180° conduction mode. The fundamental frequency of the output voltage is 50 Hz. If the DC input voltage of the inverter is 100 V and the value of the load inductance is 20 mH, the peak-to-peak load current in amperes is _____ (rounded off to the nearest integer).</p>

Q.64 In the DC-DC converter shown in the figure, the current through the inductor is continuous. The switching frequency is 500 Hz. The voltage (V_o) across the load is assumed to be constant and ripple free. The peak inductor current in amperes is _____ (rounded off to the nearest integer).

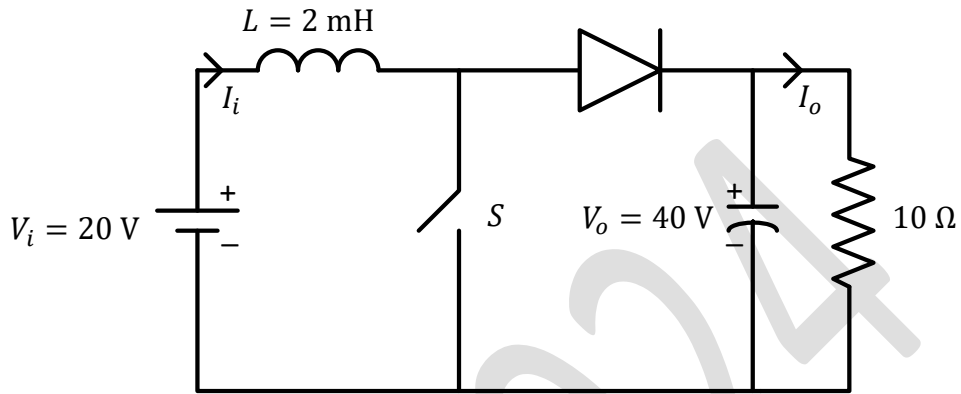

Q.65 A single-phase full-controlled thyristor converter bridge is used for regenerative braking of a separately excited DC motor with the following specifications:

Rated armature voltage	210 V
Rated armature current	10 A
Rated speed	1200 rpm
Armature resistance	1 Ω
Input to the converter bridge	240 V at 50 Hz
The armature of the DC motor is fed from the full-controlled bridge and the field current is kept constant.	

Assume that the motor is running at 600 rpm and the armature terminals of the motor are suitably reversed for regenerative braking. If the armature current of the motor is to be maintained at the rated value, the triggering angle of the converter bridge in degrees should be _____ (rounded off to 2 decimal places).