



### IN: Instrumentation Engineering

### GA - General Aptitude

#### Q1 - Q5 carry one mark each.

- Q.No. 1 He is known for his unscrupulous ways. He always sheds \_\_\_\_\_ tears to deceive people.
- (A) fox's  
(B) crocodile's  
(C) crocodile  
(D) fox
- Q.No. 2 Jofra Archer, the England fast bowler, is \_\_\_\_\_ than accurate.
- (A) more fast  
(B) faster  
(C) less fast  
(D) more faster
- Q.No. 3 Select the word that fits the analogy:  
Build : Building :: Grow : \_\_\_\_\_
- (A) Grown  
(B) Grew  
(C) Growth  
(D) Growed
- Q.No. 4 I do not think you know the case well enough to have opinions. Having said that, I agree with your other point.  
What does the phrase "having said that" mean in the given text?
- (A) as opposed to what I have said  
(B) despite what I have said  
(C) in addition to what I have said  
(D) contrary to what I have said
- Q.No. 5 Define  $[x]$  as the greatest integer less than or equal to  $x$ , for each  $x \in (-\infty, \infty)$ . If  $y = [x]$ , then area under  $y$  for  $x \in [1,4]$  is \_\_\_\_\_.
- (A) 1  
(B) 3  
(C) 4  
(D) 6

#### Q6 - Q10 carry two marks each.

- Q.No. 6 Crowd funding deals with mobilisation of funds for a project from a large number of people, who would be willing to invest smaller amounts through web-based platforms in the project.
- Based on the above paragraph, which of the following is correct about crowd funding?
- (A) Funds raised through unwilling contributions on web-based platforms.  
(B) Funds raised through large contributions on web-based platforms.

- (C) Funds raised through coerced contributions on web-based platforms.
- (D) Funds raised through voluntary contributions on web-based platforms.

Q.No. 7 P, Q, R and S are to be uniquely coded using  $\alpha$  and  $\beta$ . If P is coded as  $\alpha\alpha$  and Q as  $\alpha\beta$ , then R and S, respectively, can be coded as \_\_\_\_\_.

- (A)  $\beta\alpha$  and  $\alpha\beta$
- (B)  $\beta\beta$  and  $\alpha\alpha$
- (C)  $\alpha\beta$  and  $\beta\beta$
- (D)  $\beta\alpha$  and  $\beta\beta$

Q.No. 8 The sum of the first  $n$  terms in the sequence 8, 88, 888, 8888, ... is\_\_\_\_\_.

- (A)  $\frac{81}{80}(10^n - 1) + \frac{9}{8}n$
- (B)  $\frac{81}{80}(10^n - 1) - \frac{9}{8}n$
- (C)  $\frac{80}{81}(10^n - 1) + \frac{8}{9}n$
- (D)  $\frac{80}{81}(10^n - 1) - \frac{8}{9}n$

Q.No. 9 Select the graph that schematically represents BOTH  $y = x^m$  and  $y = x^{1/m}$  properly in the interval  $0 \leq x \leq 1$ , for integer values of  $m$ , where  $m > 1$ .

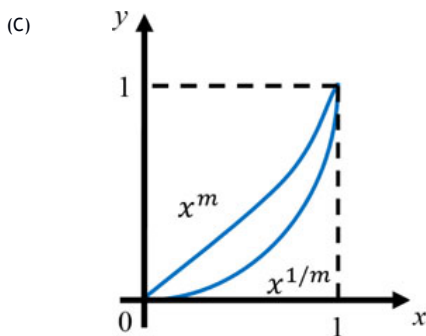
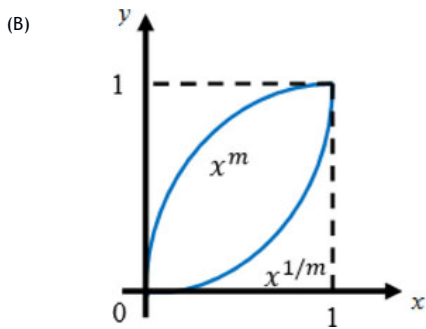
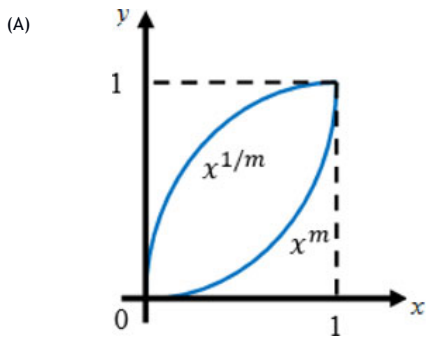

(D)

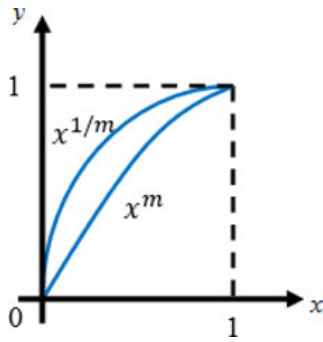

- Q.No. 10 The bar graph shows the data of the students who appeared and passed in an examination for four schools P, Q, R and S. The average of success rates (in percentage) of these four schools is \_\_\_\_\_.

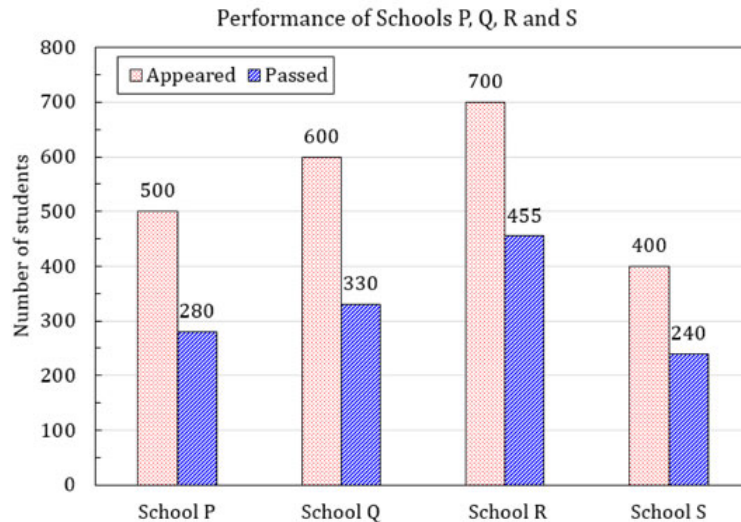

- (A) 58.5 %  
 (B) 58.8 %  
 (C) 59.0 %  
 (D) 59.3 %

## IN: Instrumentation Engineering

### Q1 - Q25 carry one mark each.

- Q.No. 1 The unit vectors along the mutually perpendicular  $x$ ,  $y$  and  $z$  axes are  $\hat{i}$ ,  $\hat{j}$  and  $\hat{k}$  respectively. Consider the plane  $z = 0$  and two vectors  $\vec{a}$  and  $\vec{b}$  on that plane such that  $\vec{a} \neq \alpha \vec{b}$  for any scalar  $\alpha$ . A vector perpendicular to both  $\vec{a}$  and  $\vec{b}$  is \_\_\_\_.
- (A)  $\hat{k}$   
 (B)  $\hat{i} - \hat{j}$   
 (C)  $-\hat{j}$   
 (D)  $\hat{i}$
- Q.No. 2 Consider the recursive equation  $X_{n+1} = X_n - h(F(X_n) - X_n)$ , with initial condition  $X_0 = 1$  and  $h > 0$  being a very small valued scalar. This recursion numerically solves the ordinary differential equation \_\_\_\_
- (A)  $\dot{X} = -F(X), X(0) = 1$   
 (B)  $\dot{X} = -F(X) + X, X(0) = 1$   
 (C)  $\dot{X} = F(X), X(0) = 1$   
 (D)  $\dot{X} = F(X) + X, X(0) = 1$

Q.No. 3

A set of linear equations is given in the form  $Ax = b$ , where  $A$  is a  $2 \times 4$  matrix with real number entries and  $b \neq 0$ . Will it be possible to solve for  $x$  and obtain a **unique solution** by multiplying both left and right sides of the equation by  $A^T$  (the super script  $T$  denotes the transpose) and inverting the matrix  $A^T A$  ? Answer is \_\_\_

- (A) Yes, it is always possible to get a unique solution for any  $2 \times 4$  matrix  $A$ .
- (B) No, it is not possible to get a unique solution for any  $2 \times 4$  matrix  $A$ .
- (C) Yes, can obtain a unique solution provided the matrix  $A^T A$  is well conditioned
- (D) Yes, can obtain a unique solution provided the matrix  $A$  is well conditioned

Q.No. 4 In the circuit shown below, the safe maximum value for the current  $I$  is \_\_\_

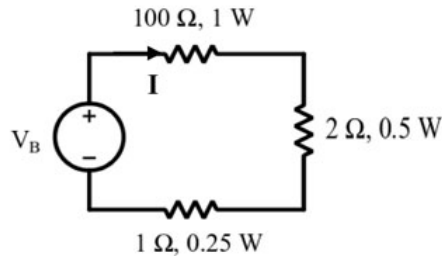

- (A) 1.0 A
- (B) 0.5 A
- (C) 0.1 A
- (D) 0.05 A

Q.No. 5 A differentiator has a transfer function whose

- (A) phase increases linearly with frequency
- (B) magnitude remains constant
- (C) magnitude increases linearly with frequency
- (D) magnitude decreases linearly with frequency

Q.No. 6 A phase lead network has the transfer function  $G(s) = \frac{1+0.2s}{1+0.05s}$ . The angular frequency at which the maximum phase shift for the network occurs is \_\_\_

- (A) 10 rad/s
- (B) 20 rad/s
- (C) 100 rad/s
- (D) 200 rad/s

Q.No. 7 If the diodes in the circuit shown are ideal and the breakdown voltage  $V_Z$  of the Zener diode is 5 V, the power dissipated in the  $100 \Omega$  resistor (**in watts**) is \_\_\_

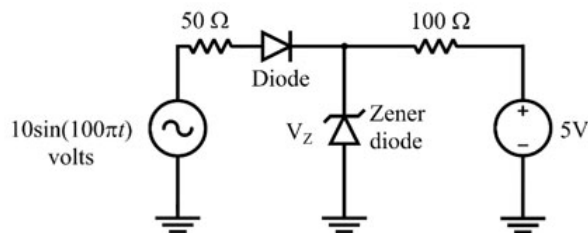

- (A) 0
- (B) 1
- (C) 25/100
- (D) 225/100

Q.No. 8

Given  $f(A, B, C, D) = \sum m(0, 1, 2, 6, 8, 9, 10, 11) + \sum d(3, 7, 14, 15)$  is a Boolean function, where  $m$  represents min-terms and  $d$  represents don't-cares. The minimal sum of products expression for  $f$  is \_\_\_\_

- (A)  $f = \overline{A}\overline{B} + CB$
- (B)  $f = \overline{B} + C$
- (C)  $f = \overline{D} + A$
- (D)  $f = \overline{A}B + \overline{C}D$

Q.No. 9 A Q meter is best suited for the measurement of the \_\_\_\_

- (A) Quality factor of a capacitance.
- (B) Distributed capacitance of a coil.
- (C) Quality factor of piezoelectric sensor.
- (D) Turns-ratio of a transformer

Q.No. 10 If  $I$  is the current flowing through a Hall effect sensor and  $B$  is the magnetic flux density perpendicular to the direction of the current (in the plane of the Hall effect sensor), the Hall voltage generated is \_\_\_\_

- (A) Directly proportional to  $I$  and inversely proportional to  $B$
- (B) Directly proportional to both  $I$  and  $B$
- (C) Inversely proportional to both  $I$  and  $B$
- (D) Inversely proportional to  $I$  and directly proportional to  $B$

Q.No. 11 The Boolean expression for the shaded regions as shown in the figure is \_\_\_\_

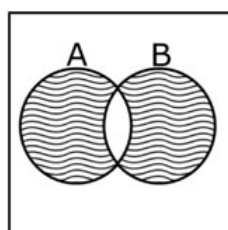

- (A)  $(A+B) \cdot (\overline{A} + \overline{B})$
- (B)  $(A + \overline{B}) \cdot (\overline{A} + B)$
- (C)  $(\overline{A} + B) \cdot (\overline{A} + \overline{B})$
- (D)  $(\overline{A} + \overline{B}) \cdot (A + \overline{B})$

Q.No. 12 The Boolean operation performed by the following circuit at the output O is \_\_\_\_

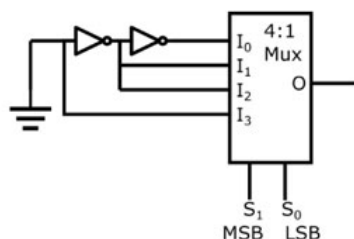

- (A)  $O = S_1 \oplus S_0$
- (B)  $O = S_1 \cdot \overline{S_0}$
- (C)  $O = S_1 + S_0$
- (D)  $O = S_0 \cdot \overline{S_1}$

Q.No. 13

Consider the Signal  $x[n] = \sin(2\pi n) u[n]$ , where  $u[n] = \begin{cases} 1 & n = 0,1,2,3, \dots \\ 0 & \text{otherwise} \end{cases}$

The period of this signal  $x[n]$  is \_\_\_\_

- (A) 4
- (B) 3
- (C) 2
- (D) 1

Q.No. 14 The closed loop transfer function of a control system is given by  $\frac{C(s)}{R(s)} = \frac{1}{s+1}$ . For the input  $r(t) = \sin t$ , the steady state response  $c(t)$  is \_\_\_\_

- (A) 1
- (B)  $\frac{1}{\sqrt{2}} \cos t$
- (C)  $\frac{1}{\sqrt{2}} \sin\left(t + \frac{\pi}{4}\right)$
- (D)  $\frac{1}{\sqrt{2}} \sin\left(t - \frac{\pi}{4}\right)$

Q.No. 15 Let  $f(z) = \frac{1}{z+a}, a > 0$ . The value of the integral  $\oint_C f(z) dz$  over a circle  $C$  with center  $(-a, 0)$  and radius  $R > 0$  evaluated in the anti-clockwise direction is \_\_\_\_

- (A) 0
- (B)  $2\pi i$
- (C)  $-2\pi i$
- (D)  $4\pi i$

Q.No. 16 A player throws a ball at a basket kept at a distance. The probability that the ball falls into the basket in a single attempt is 0.1. The player attempts to throw the ball twice. Considering each attempt to be independent, the probability that this player puts the ball into the basket only in the second attempt (**rounded off to two decimal places**) is \_\_\_\_

Q.No. 17 Assuming ideal opamps, the output voltage at  $V_1$  in the figure shown (**in volts**) is \_\_\_\_

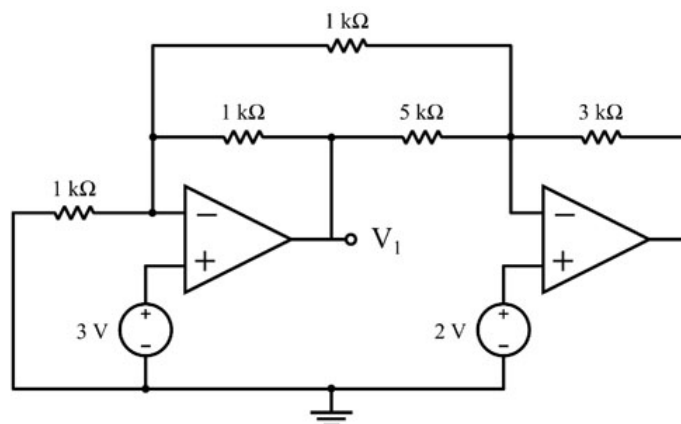

Q.No. 18 Three  $400 \Omega$  resistors are connected in delta and powered by a 400 V (rms), 50 Hz, balanced, symmetrical R-Y-B sequence, three-phase three-wire mains. The rms value of the **line current** (**in amperes, rounded off to one decimal place**) is \_\_\_\_

Q.No. 19 Consider the signal  $x(t) = e^{-|t|}$ . Let  $X(j\omega) = \int_{-\infty}^{\infty} x(t) e^{-j\omega t} dt$  be the Fourier transform of  $x(t)$ . The value of  $X(j0)$  is \_\_\_\_

Q.No. 20 A second order system has closed loop poles located at  $s = -3 \pm j4$ . The time  $t$  at which the maximum value of the step response occurs (**in seconds, rounded off to two decimal places**) is \_\_\_\_

Q.No. 21 Assume that the opamp in the circuit shown is ideal.

The value of  $\frac{V_x}{I_x}$  (**in k $\Omega$** ) is \_\_\_\_

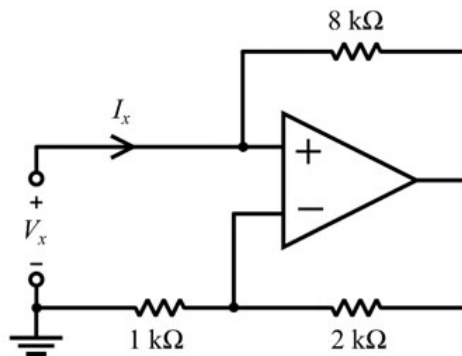

Q.No. 22 A sinusoid of 10 kHz is sampled at 15 k samples/s. The resulting signal is passed through an ideal low pass filter (LPF) with cut-off frequency of 25 kHz. The maximum frequency component at the output of the LPF (**in kHz**) is \_\_\_\_

Q.No. 23 A 200 mV full-scale dual-slope analog to digital converter (DS-ADC) has a reference voltage of 100 mV. The first integration time is set as 100 ms. The DS-ADC is operated in the continuous conversion mode. The conversion time of the DS-ADC for an input voltage of 123.4 mV (**in ms, rounded off to one decimal place**) is \_\_\_\_

Q.No. 24 The capacitance  $C_x$  of a capacitive type sensor is  $(1000 \cdot x)$  pF, where  $x$  is the input to the sensor. As shown in the figure, the sensor is excited by a voltage  $10 \sin(100\pi t)$  V. The other terminal of the sensor is tied to the input of a high input impedance amplifier through a shielded cable, with shield connected to ground. The cable capacitance is 100 pF. The peak of the voltage  $V_A$  at the input of the amplifier when  $x = 0.1$  (**in volts**) is \_\_\_\_

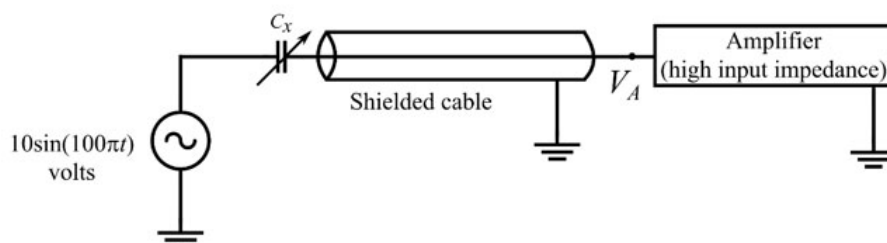

Q.No. 25 Two 100  $\Omega$  resistors having tolerance 3 % and 4 % are connected in series. The effective tolerance of the series combination (**in %, rounded off to one decimal place**) is \_\_\_\_

**Q26 - Q55 carry two marks each.**

Q.No. 26

Consider the matrix  $M = \begin{bmatrix} 1 & -1 & 0 \\ 1 & -2 & 1 \\ 0 & -1 & 1 \end{bmatrix}$ . One of the eigenvectors of  $M$  is

- (A)  $\begin{bmatrix} 1 \\ -1 \\ 1 \end{bmatrix}$
- (B)  $\begin{bmatrix} 1 \\ 1 \\ -1 \end{bmatrix}$
- (C)  $\begin{bmatrix} -1 \\ 1 \\ -1 \end{bmatrix}$
- (D)  $\begin{bmatrix} 1 \\ 1 \\ 1 \end{bmatrix}$

Q.No. 27

Consider the differential equation  $\frac{dx}{dt} = \sin(x)$ , with the initial condition  $x(0) = 0$ .

The solution to this ordinary differential equation is \_\_\_\_

- (A)  $x(t) = 0$
- (B)  $x(t) = \sin(t)$
- (C)  $x(t) = \cos(t)$
- (D)  $x(t) = \sin(t) - \cos(t)$

Q.No. 28

A straight line drawn on an x-y plane intercepts the x-axis at  $-0.5$  and the y-axis at  $1$ .

The equation that describes this line is \_\_\_\_

- (A)  $y = -0.5x + 1$
- (B)  $y = x - 0.5$
- (C)  $y = 0.5x - 1$
- (D)  $y = 2x + 1$

Q.No. 29

The loop transfer function of a negative feedback system is  $G(s)H(s) = \frac{1}{s(s-2)}$ . The

Nyquist plot for the above system \_\_\_\_

- (A) encircles  $(-1 + j0)$  point once in the clockwise direction
- (B) encircles  $(-1 + j0)$  point once in the counterclockwise direction
- (C) does not encircle  $(-1 + j0)$  point
- (D) encircles  $(-1 + j0)$  point twice in the counterclockwise direction

Q.No. 30

$I_1$ ,  $I_2$  and  $I_3$  in the figure below are mesh currents. The correct set of mesh equations for these currents, in matrix form, is \_\_\_\_

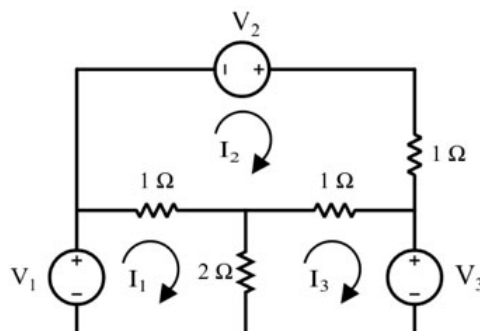

- (A)  $\begin{bmatrix} 3 & -1 & -2 \\ -1 & 3 & -1 \\ -2 & -1 & 3 \end{bmatrix} \begin{bmatrix} I_1 \\ I_2 \\ I_3 \end{bmatrix} = \begin{bmatrix} V_1 \\ V_2 \\ -V_3 \end{bmatrix}$



- (B) 
$$\begin{bmatrix} 3 & -1 & -2 \\ -1 & 3 & -1 \\ -2 & -1 & -3 \end{bmatrix} \begin{bmatrix} I_1 \\ I_2 \\ I_3 \end{bmatrix} = \begin{bmatrix} V_1 \\ V_2 \\ V_3 \end{bmatrix}$$
- (C) 
$$\begin{bmatrix} -3 & -1 & -2 \\ -1 & 3 & -1 \\ -2 & -1 & 3 \end{bmatrix} \begin{bmatrix} I_1 \\ I_2 \\ I_3 \end{bmatrix} = \begin{bmatrix} V_1 \\ V_2 \\ -V_3 \end{bmatrix}$$
- (D) 
$$\begin{bmatrix} 1 & -1 & -2 \\ -1 & 2 & -1 \\ -2 & -1 & 3 \end{bmatrix} \begin{bmatrix} I_1 \\ I_2 \\ I_3 \end{bmatrix} = \begin{bmatrix} V_1 \\ V_2 \\ V_3 \end{bmatrix}$$

Q.No. 31 Consider the function  $f(x, y) = x^2 + y^2$ . The minimum value the function attains on the line  $x + y = 1$  (**rounded off to one decimal place**) is \_\_\_\_

Q.No. 32 Consider two identical bags B1 and B2 each containing 10 balls of identical shapes and sizes. Bag B1 contains 7 Red and 3 Green balls, while bag B2 contains 3 Red and 7 Green balls. A bag is picked at random and a ball is drawn from it, which was found to be Red. The probability that the Red ball came from bag B1 (**rounded off to one decimal place**) is \_\_\_\_

Q.No. 33 The rms value of the phasor current  $I$  in the circuit shown (**in amperes**) is \_\_\_\_

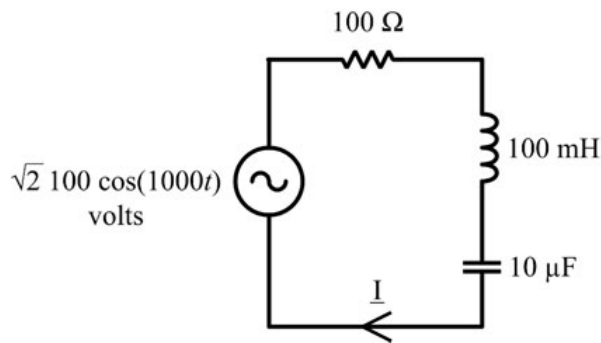

Q.No. 34 In the circuit shown, the rms value of the voltage across the  $100 \Omega$  resistor (**in volts**) is \_\_\_\_

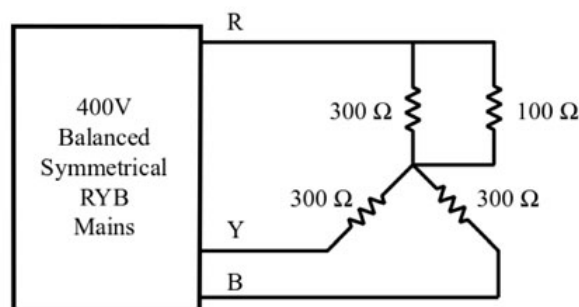

Q.No. 35 Let  $g[n] = \begin{cases} 1 & n = 0 \\ 0 & n = \pm 1, \pm 2, \pm 3, \dots \end{cases}$  and  $h[n] = \begin{cases} 1 & n = 0, 3, 6, 9, \dots \\ 0 & \text{otherwise} \end{cases}$ .

Consider  $y[n] = h[n] \otimes g[n]$ , where  $\otimes$  denotes the convolution operator. The value of  $y[2]$  is \_\_\_\_

Q.No. 36 The loop transfer function of a negative feedback system is given by

$G(s)H(s) = \frac{K}{s(s+2)(s+6)}$ , where  $K > 0$ . The value of  $K$  at the breakaway point of the root locus for the above system (**rounded off to one decimal place**) is \_\_\_\_

Q.No. 37 The system shown in Fig. (a) has a time response  $y(t)$  to an input  $r(t) = 10 u(t)$  as shown in Fig. (b),  $u(t)$  being the unit step input. Both  $K$ ,  $\tau$  are positive. The gain  $K$  of the system is \_\_\_\_

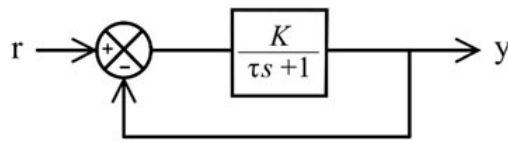

Fig. (a)

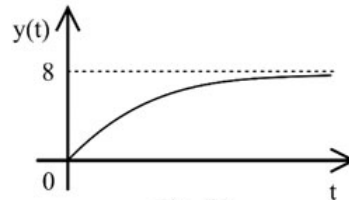
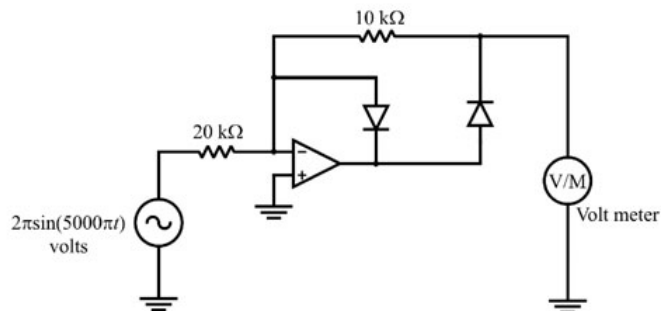
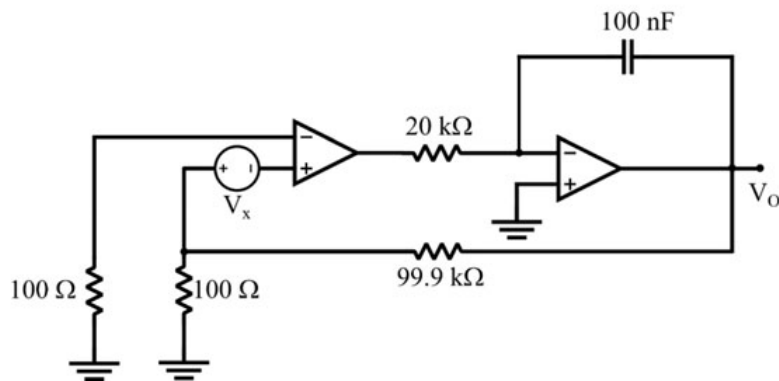

Fig. (b)

Q.No. 38 Assuming that the opamp used in the circuit shown is ideal, the reading of the 1 Hz bandwidth, permanent magnet moving coil (PMMC) type voltmeter (in volts) is \_\_\_\_



Q.No. 39 If the opamps in the circuit shown are ideal and  $V_x = 0.5$  mV, the steady state value of  $V_o$  (in volts, rounded off to two decimal places) is \_\_\_\_



Q.No. 40

Two T-flip flops are interconnected as shown in the figure. The present state of the flip flops are:  $A = 1$ ,  $B = 1$ . The input  $x$  is given as 1, 0, 1 in the next three clock cycles. The decimal equivalent of  $(AB)_2$  with  $A$  being the MSB and  $y$  being the LSB, after the 3<sup>rd</sup> clock cycle is \_\_\_\_

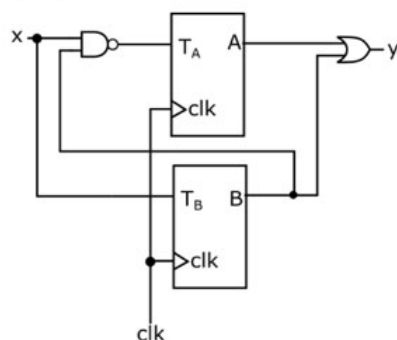

Q.No. 41 The address lines  $A_9 \dots A_2$  of a 10 bit, 1.023 V full-scale digital to analog converter (DAC) is connected to the data lines  $D_7$  to  $D_0$  of an 8-bit microprocessor, with  $A_1$  and  $A_0$  of the DAC grounded. Now,  $D_7 \dots D_0$  is changed from 1010 1010 to 1010 1011. The corresponding change in the output of the DAC (in mV, rounded off to one decimal place) is \_\_\_\_

Q.No. 42 The real power drawn by a balanced load connected to a 400 V, 50 Hz, balanced, symmetrical 3-phase, 3-wire, RYB sequence mains is measured using the two-wattmeter method. Wattmeter  $W_1$  is connected in the R line and wattmeter  $W_2$  is connected in the B line. The line current is measured as  $\frac{1}{\sqrt{3}}$  A. If the wattmeter  $W_1$  reads zero, the reading on  $W_2$  (in watts) is \_\_\_\_

Q.No. 43 A  $6\frac{1}{2}$  digit timer-counter is set in the 'time period' mode of operation and the range is set as 'ns'. For an input signal, the timer-counter displays 1000000. With the same input signal, the timer-counter is changed to 'frequency' mode of operation and the range is set as 'Hz'. The display will show the number \_\_\_\_

Q.No. 44 The circuit shown uses ideal opamp powered from a supply  $V_{CC} = 5$  V. If the charge  $q_p$  generated by the piezoelectric sensor is of the form  $q_p = 0.1 \sin(10000\pi t)$   $\mu\text{C}$ , the peak detector output after 10 cycles of  $q_p$  (in volts, rounded off to one decimal place) is \_\_\_\_

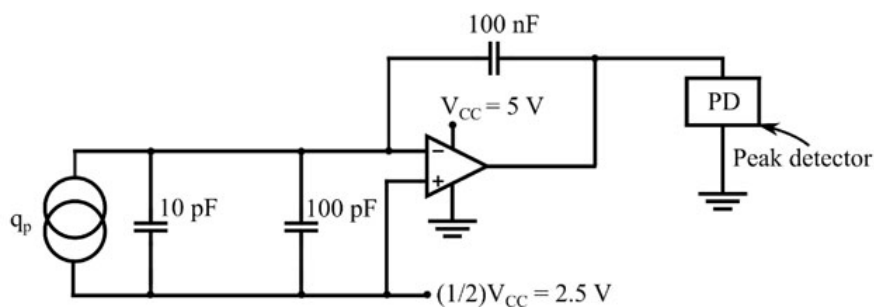

Q.No. 45

A metallic strain gauge of resistance  $R_x$  with a gauge factor of 2 is bonded to a structure made of a metal with modulus of elasticity of  $200 \text{ GN/m}^2$ . The value of  $R_x$  is  $1 \text{ k}\Omega$  when no stress is applied.  $R_x$  is a part of a quarter bridge with three identical fixed resistors of  $1 \text{ k}\Omega$  each. The bridge is excited from a DC voltage of  $4 \text{ V}$ . The structure is subjected to a stress of  $100 \text{ MN/m}^2$ . Magnitude of the output of the bridge (in mV, rounded off to two decimal places) is \_\_\_\_

Q.No. 46 A laser beam of  $10 \text{ mm}$  beam diameter is focused onto an optical fibre using a thin biconvex lens as shown in the figure. The refractive index of the lens is  $1.5$ . The refractive indices of the core and cladding of the fibre are  $1.55$  and  $1.54$  respectively. The minimum value of the focal length of the lens to attain the maximum coupling to the fibre (in mm, rounded off to one decimal place) is \_\_\_\_

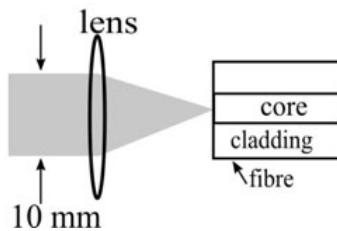

Q.No. 47 As shown in the figure, a slab of finite thickness  $t$  with refractive index  $n_2 = 1.5$ , has air ( $n_1 = 1$ ) above and below it. Light of free space wavelength  $600 \text{ nm}$  is incident normally from air as shown. For a destructive interference to be observed at R, the minimum value of thickness of the slab  $t$  (in nm) is \_\_\_\_

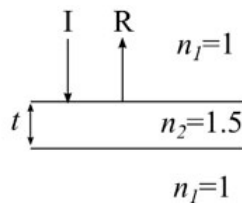

Q.No. 48 Consider the finite sequence  $X = (1, 1, 1)$ . The Inverse Discrete Fourier Transform (IDFT) of  $X$  is given as  $(x(0), x(1), x(2))$ . The value of  $x(2)$  is \_\_\_\_

Q.No. 49 A circuit consisting of capacitors, DC voltage source and an amplifier having a voltage gain  $G = -5$  is shown in the figure. The effective capacitance across the nodes A and B (in  $\mu\text{F}$ , rounded off to one decimal place) is \_\_\_\_

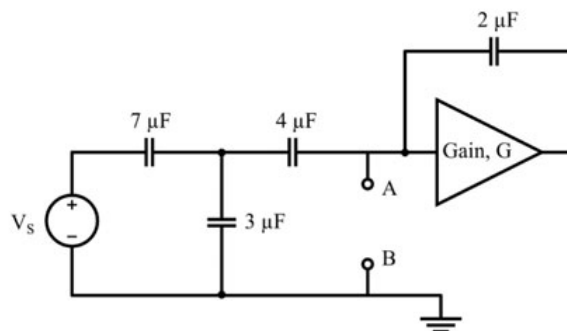

Q.No. 50

Consider the following state variable equations:

$$\dot{x}_1(t) = x_2(t)$$

$$\dot{x}_2(t) = -6x_1(t) - 5x_2(t)$$

The initial conditions are  $x_1(0) = 0$  and  $x_2(0) = 1$ . At  $t = 1$  second, the value of  $x_2(1)$  (**rounded off to two decimal places**) is \_\_\_\_

- Q.No. 51 Assume the diodes in the circuit shown are ideal. The current  $I_x$  flowing through the  $3\text{ k}\Omega$  resistor (**in mA, rounded off to one decimal place**) is \_\_\_\_

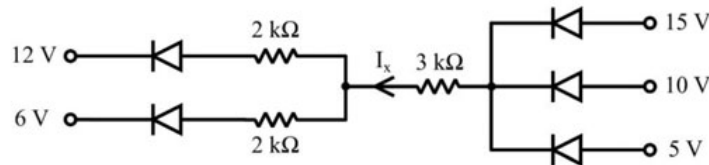

- Q.No. 52 A  $1000/1\text{ A}$ ,  $5\text{ VA}$ , UPF bar-primary measuring current transformer has 1000 secondary turns. The current transformer exhibits a ratio error of  $-0.1\%$  and a phase error of  $3.438$  minutes when the primary current is  $1000\text{ A}$ . At this operating condition, the rms value of the magnetization current of the current transformer (**in amperes, rounded off to two decimal places**) is \_\_\_\_

- Q.No. 53 The mutual inductances between the primary coil and the secondary coils of a linear variable differential transformer (LVDT) shown in the figure are  $M_1$  and  $M_2$ . Assume that the self-inductances  $L_{S1}$  and  $L_{S2}$  remain constant and are independent of  $x$ . When  $x = 0$ ,  $M_1 = M_2 = M_0$ . When  $x$  is in the range  $\pm 10\text{ mm}$ ,  $M_1$  and  $M_2$  change linearly with  $x$ . At  $x = +10\text{ mm}$  or  $-10\text{ mm}$ , the change in the magnitudes of  $M_1$  and  $M_2$  is  $0.25 M_0$ . For a particular displacement  $x = D$ , the voltage across the detector becomes zero when  $|V_2| = 1.25|V_1|$ . The value of  $D$  (**in mm, rounded off to one decimal place**) is \_\_\_\_

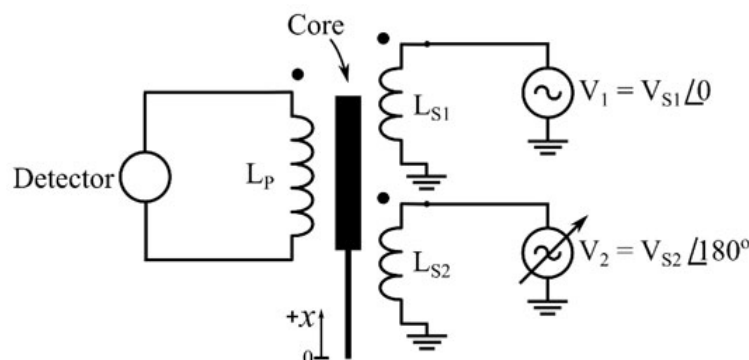

- Q.No. 54

In the Maxwell-Wien bridge shown, the detector D reads zero when  $C_1 = 100 \text{ nF}$  and  $R_1 = 100 \text{ k}\Omega$ . The Q factor of the coil is \_\_\_\_

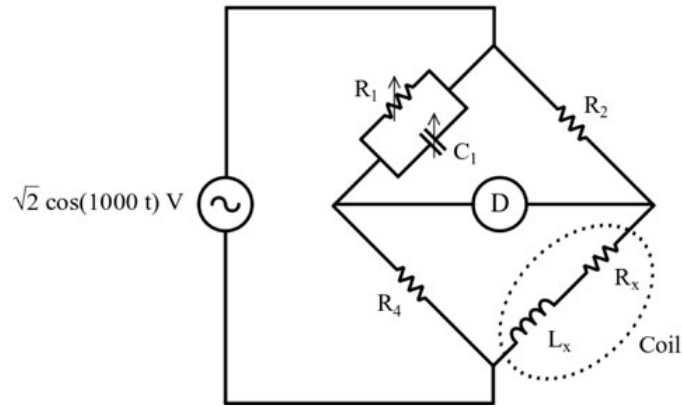

Q.No. 55 The loop transfer function of a negative feedback system is  $G(s)H(s) = \frac{2(s+1)}{s^2}$ . The phase margin of the system (**in degrees, rounded off to one decimal place**) is \_\_\_\_